

ISSUE No & DATE	DETAILS OF CHANGE, MODIFICATION RECORD NUMBER, ECR NUMBER.
01 19.12.18	For reference only

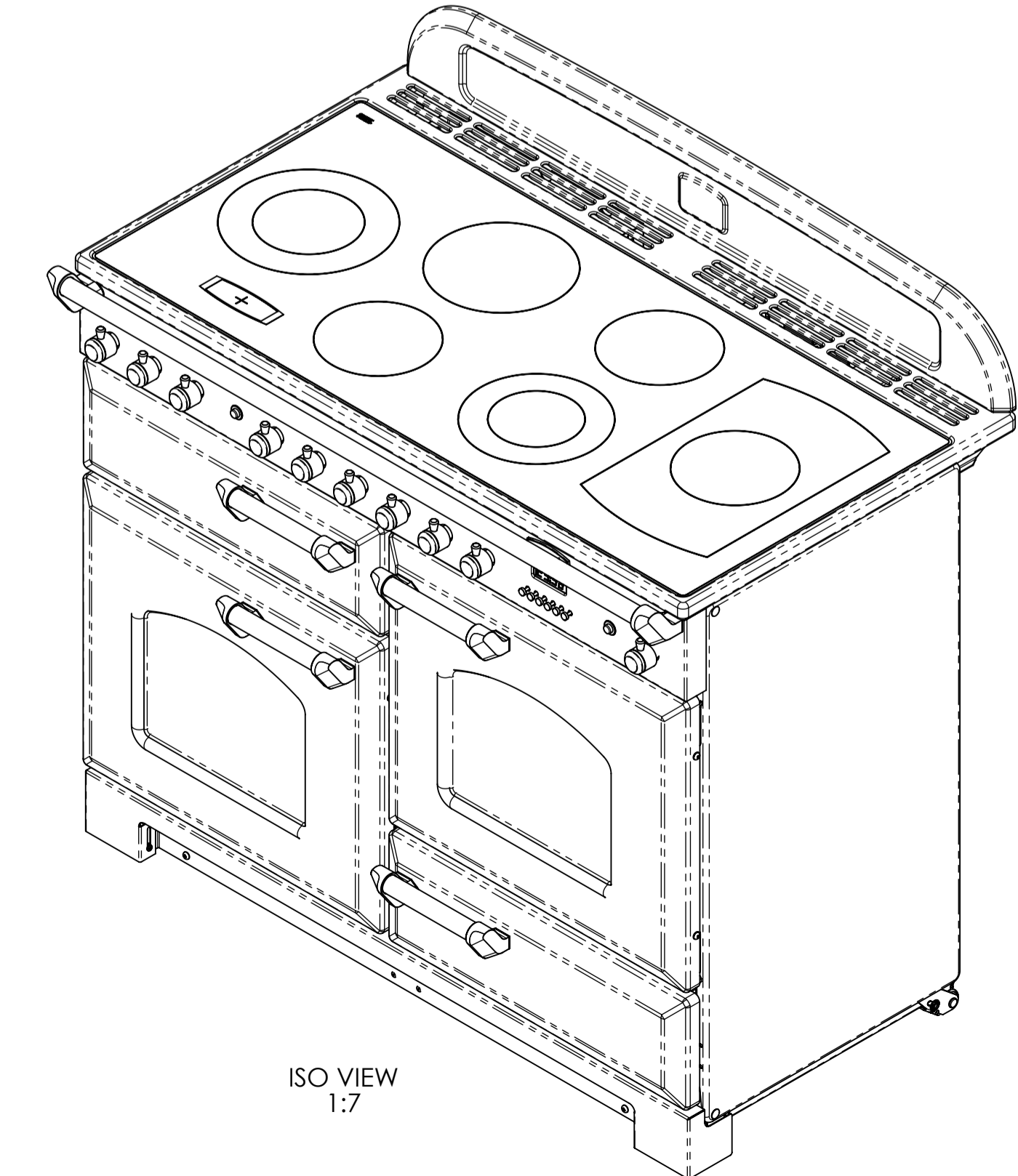
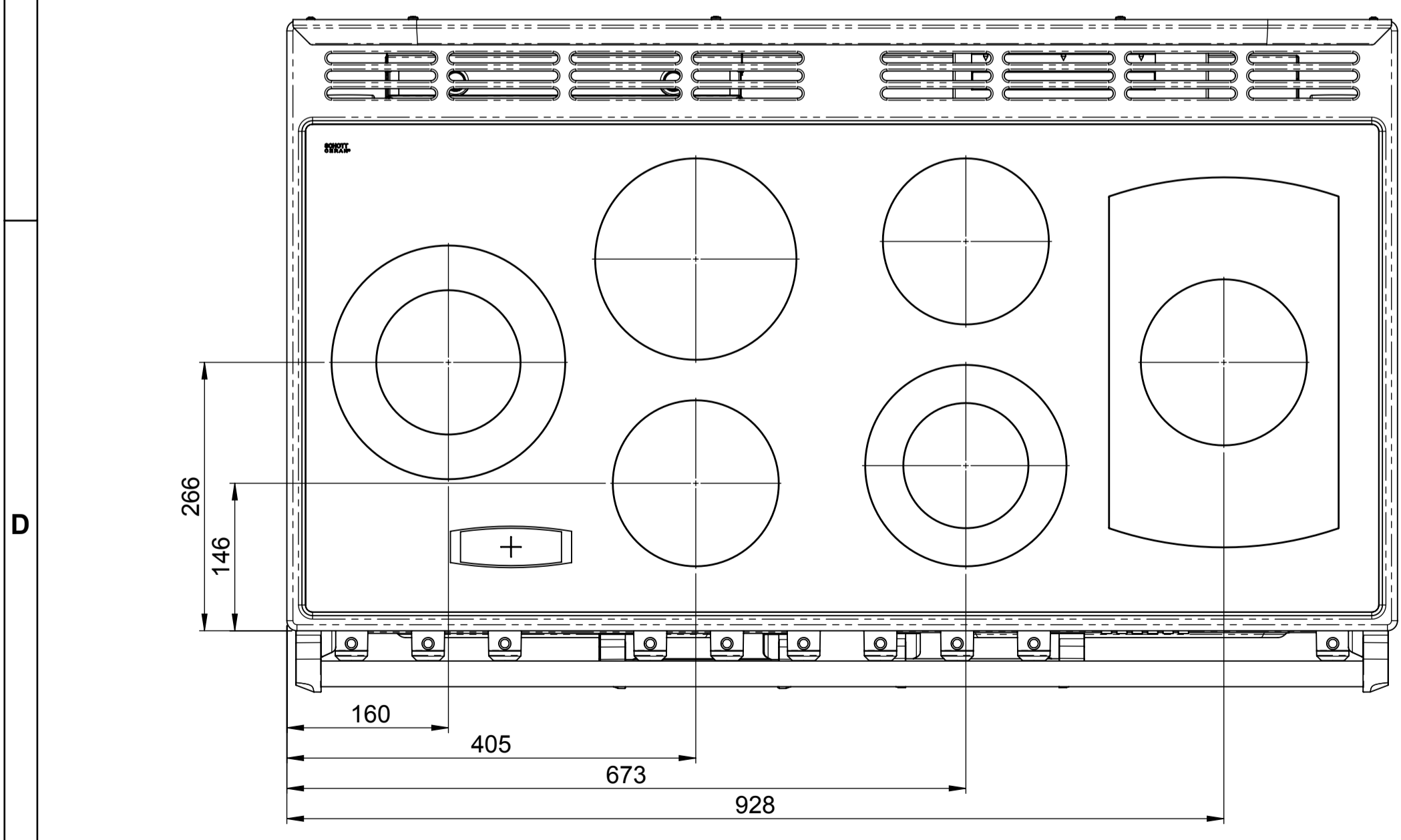
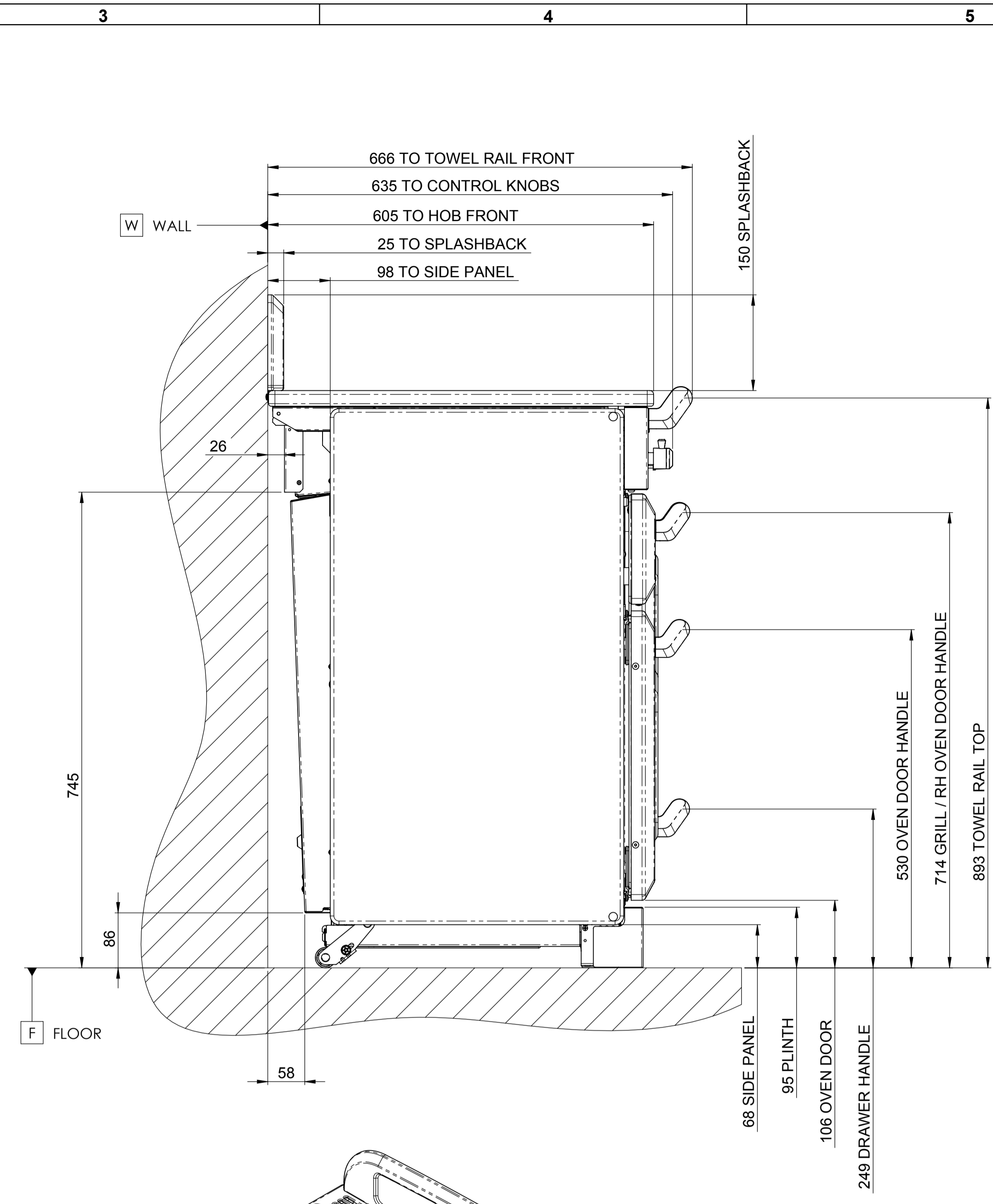
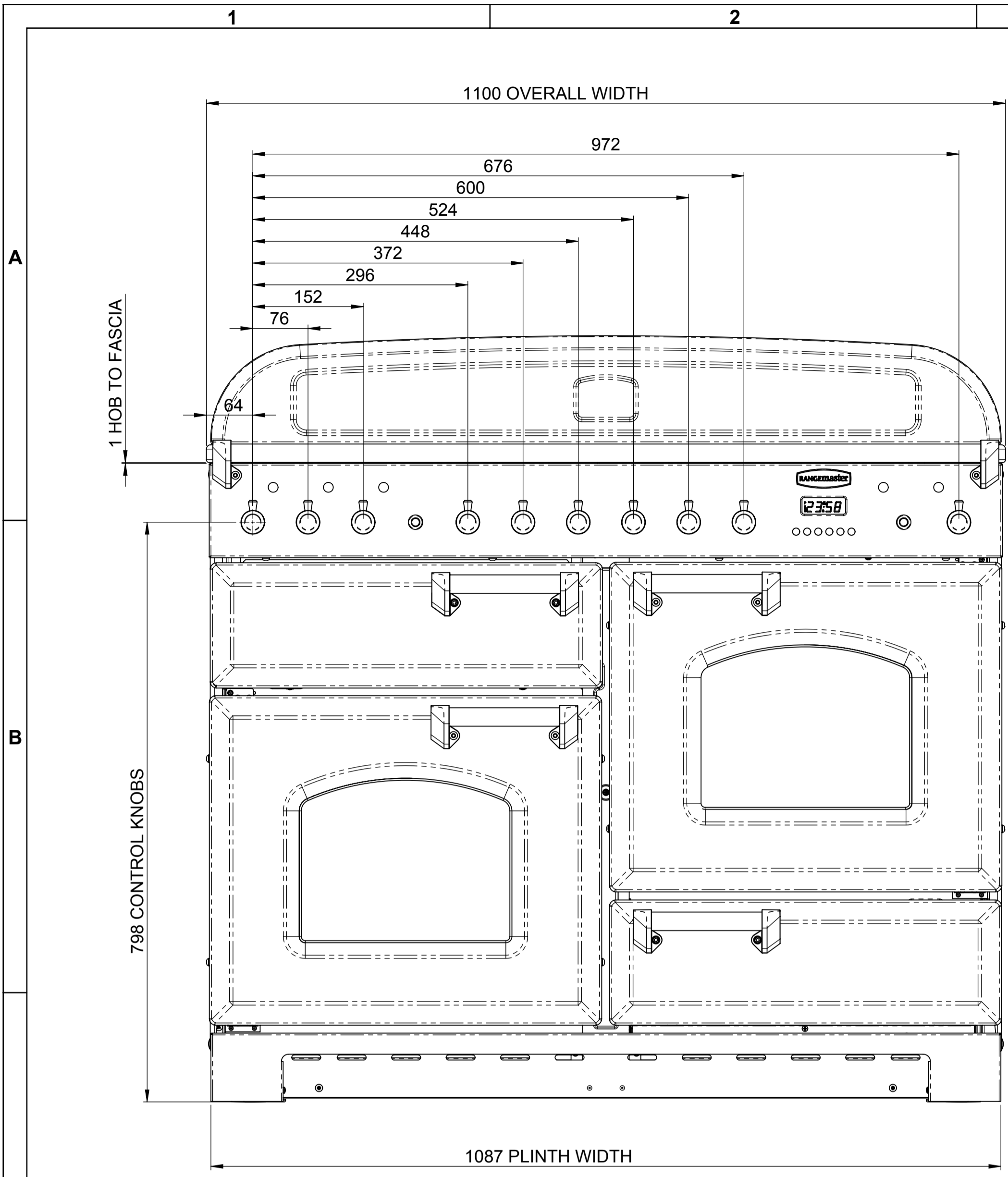

- NOTES:**
1. ALL DIMENSIONS ARE NOMINAL & ROUNDED TO THE NEAREST WHOLE NUMBER, UNLESS SHOWN OTHERWISE.
 2. ALL HEIGHT DIMENSIONS ARE BASED ON THE COOKER BEING SET AT ITS LOWEST LEVEL (IE. 935 DIMENSION), THEY WILL CHANGE ACCORDINGLY WITH THE AMOUNT OF HEIGHT ADJUSTMENT.
 3. FOR DOCUMENTATION PURPOSES THE COOKER IS HEIGHT ADJUSTABLE AS DETAILED IN OBP.
 4. THIS DRAWING IS FOR REFERENCE PURPOSES ONLY. A 'PDF' COPY OF THIS DRAWING FORMS PART OF THE 'APPLIANCE PRODUCT SPECIFICATION' HELD ON THE 'COMMON' DRIVE. CHANGES TO THIS DRAWING REQUIRE THE 'PDF' FILE TO BE UPDATED.

Clarence Street, Royal Leamington Spa
Warwickshire CV31 2AD, United Kingdom
Telephone: 44 (0)1926 457400
Direct Fax: 44 (0)1926 457611
Web: www.agarangemaster.co.uk

**DO NOT SCALE OR GUESS. IF IN DOUBT, ASK.
ALL MATERIALS MUST COMPLY WITH RoHS & REACH**

ALL MACHINING TO BE FREE FROM BURRS.
TOLERANCES UNLESS OTHERWISE STATED:-
ANGULAR ±30° WHOLE NUMBERS ±0.5
LINEAR DIMENSIONS ONE DECIMAL PLACE ±0.15
CIRCULAR HOLES ±0.15

CNC BEND RADI 1.25 -0
CNC BEND ANGLES ±2°

ALL DIMENSIONS
IN MILLIMETRES

A1 DRAWING BORDER CREATED
01/08/2012 BY D.J.B

PROJECTION

THIS DRAWING IS THE PROPERTY OF RANGEMASTER AND REPRODUCTION IN WHOLE OR PART MAY NOT BE MADE WITHOUT THEIR WRITTEN CONSENT.	
DRAWN MC	PROJECT ASSEMBLY
SCALE 1:5	
TITLE RM Classic Deluxe 110 Ceramic	
PART NUMBER A008132	