

USER GUIDE & INSTALLATION INSTRUCTIONS

Classic 110 Gas

SLOW BAKED LEG OF LAMB



INGREDIENTS

- 2–3 large sprigs of rosemary
- 4 large garlic cloves cut in half lengthways
- 1.8 kg leg of lamb
- 8 good quality anchovy fillets, halved
- 100 ml olive oil
- 250 ml dry red wine
- Maldon salt and freshly ground black pepper

METHOD

1. Preheat the oven to 220 °C (for a conventional oven), 200 °C (for a fan oven) or gas mark 7.
2. Pull the small sprigs off the rosemary branches and set aside with the garlic.
2. Using the tip of a paring knife, make up to 20 well-spaced cuts into the flesh of the lamb, about 2.5 cm inch deep. Divide the rosemary sprigs, garlic and anchovies and push down into the cuts. Place the leg on a large roasting tin and pour over the oil, massaging it all over the joint. Season well with salt and pepper and pour the wine and 250 ml water into the tin.
3. Put into the oven and sear for 15 minutes, then turn the temperature right down to 130 °C (conventional oven), 110 °C (fan oven) or gas mark 1 and roast for 4–5 hours, basting every 30 minutes or so. Basting frequently helps to keep the meat moist and encourages the build up of a good glaze on the outside. Add more liquid (wine or water) if the tin looks dry – there should always be liquid in the tin throughout this cooking process.
4. The meat is ready when it starts to fall off the bone, at which point it should have a core temperature of 90 °C. Remove from the oven, transfer to a warmed carving dish, cover loosely with foil and leave to rest in a warm place for 30–45 minutes before carving.
5. Pour the juices from the tin into a tall hi-ball glass and allow to settle. Spoon the fat from the top of the glass. There should be enough sticky, reduced juices for an intense gravy hit – if not, pour the juices you have back into the roasting tin and put it over the heat, pour in a splash of water or wine and deglaze the tin scraping up all the sticky bits from the base. Boil fast until syrupy, taste and correct the seasoning.

RASPBERRY SOUFFLÉ...



INGREDIENTS

- 400 g raspberries
- 1 tbsp lemon juice
- 100 g caster sugar
- 2 tsp crème de framboise
- 1 tsp cornflour
- 180 g egg whites (about 6)
- Pinch of cream of tartar or a squeeze of lemon juice
- Icing sugar for dusting

METHOD

1. For the soufflé, press the raspberries through a fine sieve to produce 180 g of purée. Put this into a heavy-bottomed pan, add the lemon juice and reduce down to a thick jam, stirring from time to time and being careful not to let it catch and burn.
2. Put 45 g of the sugar in a separate pan. Melt it and then boil until it becomes a thick syrup (121 °C on a sugar thermometer). To test without a thermometer, dip a teaspoon into the syrup and then dip quickly into cold water. You should be able to roll the cooling syrup into a ball between your fingers. Be careful as the syrup is extremely hot. When it has reached the right point, stir the hot syrup into the raspberry jam.
3. Mix the framboise and cornflour together and stir into the jam over the heat. Turn the jam into a small bowl, sprinkle the surface with icing sugar and cover with cling film.
4. Preheat the oven (not grill) to 180 °C shelf level 2 (conventional oven), 160 °C (fan oven) or gas mark 4 centre shelf.
5. Whisk the egg whites with the cream of tartar until you can form soft peaks, then fold in the remaining caster sugar. Lightly fold the whites into the jam, leaving thin traces of white visible in the mixture.
6. Spoon into four large buttered and sugared ramekins, place these on a baking tray and bake for 10 minutes.
7. Dust with icing sugar.

Contents

1. Before You Start...	1	6. Troubleshooting	19
Installation and Maintenance	1		
Peculiar Smells	1	7. Installation	21
If You Smell Gas	1	Dear Installer	21
Ventilation	1	Safety Requirements and Regulations	21
Personal Safety	1	Provision of Ventilation	21
Cleaning	2	Location of Cooker	22
		Positioning The Cooker	23
2. Cooker Overview	3	Moving the Cooker	23
Hotplate Burners	3	Completing the Move	24
Wok Burner	4	Fitting the Stability Bracket or Chain	24
The Wok Cradle (<i>optional extra</i>)	5	Repositioning the Cooker Following Connection	24
The Griddle	5	Levelling the Cooker	25
Warmer	5	Fitting the Oven Burner Trim	25
The Grill	6	Gas Connection	25
The Ovens	7	Electrical Connection	26
Operating the Ovens	8	Final Checks	27
The Clock	9	Final Fitting	27
Accessories	11	Customer Care	27
Main Oven Light	12		
Storage	12	8. Circuit Diagram	28
		9. Technical Data	29
3. Cooking Tips	13		
4. Cooking Table	14		
5. Cleaning Your Cooker	15		
Essential Information	15		
Hotplate Burners	15		
Grill	16		
Control Panel and Doors	16		
Ovens	17		
Cleaning Table	18		

1. Before You Start...

Thank you for buying this cooker. It should give you many years of trouble-free cooking if installed and operated correctly. It is important that you read this section before you start, particularly if you have not used a gas cooker before.

⚠ CAUTION: This appliance is for cooking purposes only. It must not be used for other purposes, for example room heating. Using it for any other purpose could invalidate any warranty or liability claim. Besides invalidating claims this wastes fuel and may overheat the control knobs.

Installation and Maintenance

All installations must be in accordance with the relevant instructions in this booklet, with the relevant national and local regulations, and with the local gas and electricity supply companies' requirements.

Make sure that the gas supply is turned on and that the cooker is wired in and switched on (the cooker needs electricity).

Set the clock to make sure that all the ovens are functional – see the relevant section in this manual.

The cooker should be serviced only by a qualified service engineer, and only approved spare parts should be used.

Always allow the cooker to cool and then switch it off at the mains before cleaning or carrying out any maintenance work, unless specified otherwise in this guide.

Peculiar Smells

When you first use your cooker it may give off an odour. This should stop after use.

Before using for the first time, make sure that all packing materials have been removed and then, to dispel manufacturing odours, turn the ovens to gas mark 6 (or 200°C) and run for at least an hour.

Before using the grill for the first time you should also turn on the grill and run for 30 minutes with the grill pan in position, pushed fully back, and the grill door open.

Make sure the room is well ventilated to the outside air (see 'Ventilation' below). People with respiratory or allergy problems should vacate the area for this brief period.

If You Smell Gas

- DO NOT turn electric switches on or off
- DO NOT smoke
- DO NOT use naked flames
- DO turn off the gas at the meter or cylinder
- DO open doors and windows to get rid of the gas
- DO keep people away from the area affected
- Call your gas supplier

Ventilation

⚠ CAUTION: The use of a gas cooking appliance results in the production of heat and moisture in the room in which it is installed. Therefore, make sure that the kitchen is well ventilated: keep natural ventilation holes open or install a powered cooker hood that vents outside. If you have several burners on, or use the cooker for a long time, open a window or turn on an extractor fan.

Personal Safety

⚠ DO NOT modify this appliance.

⚠ This appliance can be used by children aged from 8 years and above and persons with reduced physical, sensory or mental capabilities or lack of experience and knowledge if they have been given supervision or instruction concerning use of the appliance in a safe way and understand the hazards involved. Children shall not play with the appliance. Cleaning and user maintenance shall not be made by children without supervision.

⚠ WARNING: The appliance and its accessible parts become hot during use and will retain heat even after you have stopped cooking. Care should be taken to avoid touching heating elements. Children less than 8 years of age shall be kept away unless continuously supervised.

⚠ CAUTION: A long term cooking process has to be supervised from time to time. A short term cooking process has to be supervised continuously.

⚠ Danger of fire: DO NOT store items on the cooking surfaces.

⚠ To avoid overheating, DO NOT install the cooker behind a decorative door.

⚠ Accessible parts will become hot during use and will retain heat even after you have stopped cooking. Keep babies and children away from the cooker and never wear loose-fitting or hanging clothes when using the appliance.

⚠ DO NOT use a steam cleaner on your cooker.

Always be certain that the controls are in the OFF position when the oven is not in use, and before attempting to clean the cooker.

⚠ When the oven is on, DO NOT leave the oven door open for longer than necessary – otherwise, the control knobs may become very hot.

Cooking high moisture content foods can create a 'steam burst' when the oven door is opened. When opening the oven stand well back and allow any steam to disperse.

Always keep combustible materials, e.g. curtains, and flammable liquids a safe distance away from your cooker.

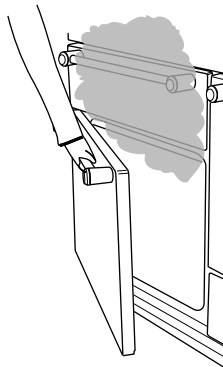

⚠ Do not spray aerosols in the vicinity of the cooker while it is on.

Use dry oven gloves when applicable – using damp gloves might result in steam burns when you touch a hot surface. Do not use a towel or other bulky cloth in place of a glove – it might catch fire if brought into contact with a hot surface.

⚠ Never operate the cooker with wet hands.

⚠ Do not use aluminium foil to cover shelves, linings or the oven roof.

⚠ DO NOT use hotplate protectors, foil or hotplate covers of any description. These may affect the safe use of your hotplate burners and are potentially hazardous to health.

⚠ Never heat unopened food containers. Pressure build up may make the containers burst and cause injury.

⚠ Do not use unstable saucepans. Always make sure that you position the handles away from the edge of the hotplate.

Never leave the hotplate unattended at high heat settings. Pans boiling over can cause smoking, and greasy spills may catch on fire. Use a deep fat thermometer whenever possible to prevent fat overheating beyond the smoking point.

⚠ WARNING! Unattended cooking on a hob with fat or oil can be dangerous and may result in fire.

⚠ NEVER leave a chip pan unattended. Always heat fat slowly, and watch as it heats. Deep fry pans should be only one third full of fat. Filling the pan too full of fat can cause spill over when food is added. If you use a combination of oils or fats in frying, stir them together before heating, or as the fats melt.

Foods for frying should be as dry as possible. Frost on frozen foods or moisture on fresh foods can cause hot fat to bubble up and over the sides of the pan. Carefully watch for spills or overheating of foods when frying at high or medium high temperatures. Never try to move a pan of hot fat, especially a deep fat fryer. Wait until the fat is cool.

Do not use the top of the flue (the slots along the back of the cooker) for warming plates, dishes, drying tea towels or softening butter.

⚠ Do not use water on grease fires and never pick up a flaming pan. Turn the controls off and then smother a flaming pan on a surface unit by covering the pan completely with a well fitting lid or baking tray. If available, use a multi-purpose dry chemical or foam-type fire extinguisher.

Take care that no water seeps into the appliance.

Only certain types of glass, glass-ceramic, earthenware or other glazed containers are suitable for hotplate cooking; others may break because of the sudden change in temperature.

This appliance is heavy, so take care when moving it.

⚠ The appliance is not intended to be operated by means of external timer or separated remote-control system.

Cleaning

In the interests of hygiene and safety, the cooker should be kept clean at all times as a build up in fats and other food stuff could result in a fire.

Clean only the parts listed in this guide.

Clean with caution. If a wet sponge or cloth is used to wipe spills on a hot surface, be careful to avoid steam burns. Some cleaners can produce noxious fumes if applied to a hot surface.

2. Cooker Overview



The 110 gas cooker (**Fig.2-1**) has the following features:

- A.** 5 hotplate burners including a wok burner and warmer
- B.** A control panel
- C.** A grill
- D.** Left-hand autogas oven
- E.** Right-hand autogas oven
- F.** A storage drawer

Hotplate Burners

The drawing by each of the central knobs indicates which burner that knob controls.

Each burner has a Flame Supervision Device (FSD) that prevents the flow of gas if the flame goes out.

When the igniter button is pressed in, sparks will be made at every burner – this is normal. Do not attempt to disassemble or clean around any burner while another burner is on, otherwise an electric shock could result.

To light a burner, press the igniter button, and push in and turn the associated control knob to the high position as indicated by the large flame symbol (🔥), (**Fig.2-2**).

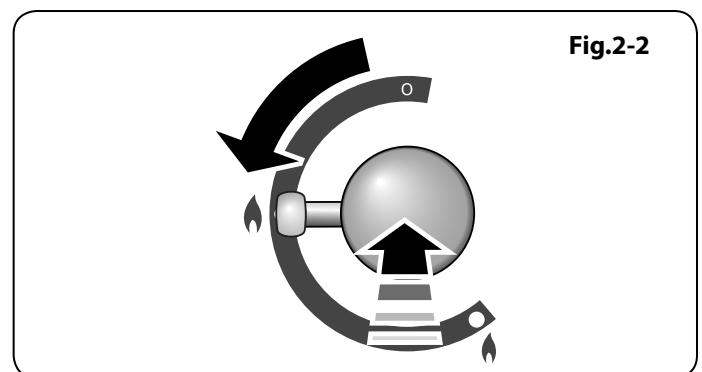
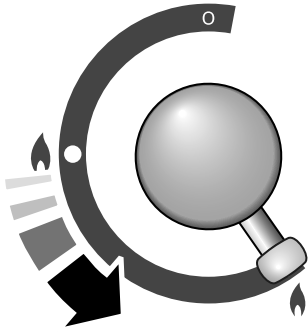

Fig.2-3



The igniter should spark and light the gas. Keep holding the knob pressed in to let the gas through to the burner for about ten seconds.

If, when you let go of the control knob, the burner goes out, then the FSD has not been bypassed. Turn the control knob to the OFF position and wait for one minute before you try again, this time making sure to hold in the control knob for slightly longer.

Adjust the flame height to suit by turning the knob counter-clockwise (**Fig.2-3**).

If a burner flame goes out, turn off the control knob and leave it for one minute before relighting it.

Fig.2-4

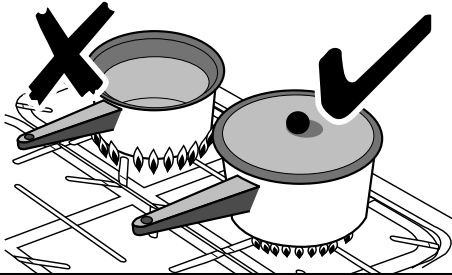

Make sure that the flames are under the pans. Using a lid will help the contents boil more quickly (**Fig.2-4**).

Large pans should be spaced well apart.

Pans and kettles with concave bases or down-turned base rims should not be used (**Fig.2-5**).

Simmering aids, such as asbestos or mesh mats, are NOT recommended (**Fig.2-6**). They will reduce burner performance and could damage the pan supports.

You should also avoid using unstable and misshapen pans that may tilt easily, and pans with a very small base diameter, e.g. milk pans, single egg poachers (**Fig.2-7**).

The minimum recommended pan diameter is 120 mm. The maximum allowable pan base diameter is 260 mm.

DO NOT use cooking vessels on the hotplate that overlap the edges.

Fig.2-5

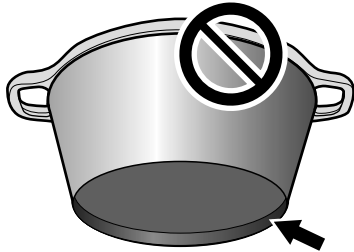
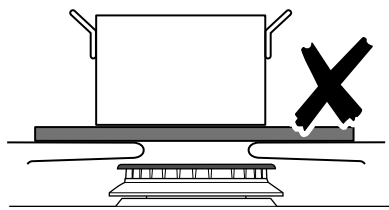

Fig.2-6



Wok Burner

The wok burner is designed to provide even heat over a large area. It is ideal for large pans and stir-frying (**Fig.2-8**).

For heating smaller pans, the aforementioned hotplate burners may be more efficient.

You should wipe the enamel top surface of the cooker around the hotplate burners as soon as possible after spills occur. Try to wipe them off while the enamel is still warm.

Note: The use of aluminium pans may cause metallic marking of the pan supports. This does not affect the durability of the enamel and may be cleaned off with an appropriate metal cleaner.

Fig.2-7

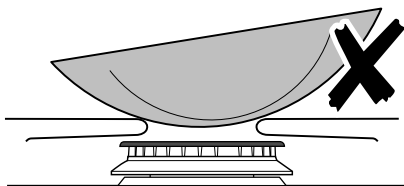
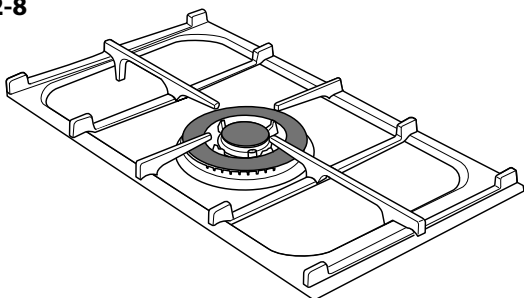

Fig.2-8



The Wok Cradle (Optional extra)

The wok cradle is designed to fit a Professional 35 cm wok. If you use a different wok, make sure that it fits the cradle. Woks vary very widely in size and shape. It is important that the wok sits down on the pan support – however, if it is too small, the cradle will not support the wok properly (Fig.2-9).

The cradle should be used on the wok burner only. When you fit the cradle (Fig.2-10), check that it is properly located on a pan support and the wok is sitting level in the cradle.

The cradle will get very hot in use – allow plenty of time for it to cool before you pick it up.

The Griddle

The griddle fits the left-hand pan support, front to back (Fig.2-11). It is designed for cooking food on directly. DO NOT use pans of any kind on it. The griddle surface is non-stick and metal cooking utensils (e.g. spatulas) will damage the surface. Use heat resistant plastic or wooden utensils.

⚠ DO NOT put it crossways – it will not fit properly and will be unstable (Fig.2-12).

⚠ DO NOT put it on any other burner – it is not designed to fit in any of the other pan supports.

Position the griddle over the hotplate burners resting on the pan support. Check that it is securely located.

The griddle can be lightly brushed with cooking oil before use (Fig.2-13). Light the hotplate burners. Adjust the flame heights to suit.

Preheat the griddle for a **maximum of 5 minutes** before adding food. Leaving it longer may cause damage. Turn the control knobs towards the low position, marked with the small flame symbol, to reduce the burner flames.

⚠ Always leave space around the griddle for the gases to escape.

⚠ NEVER fit two griddles side by side (Fig.2-14).

After cooking, allow the griddle to cool before cleaning.

Warmer

On the right of the hob is the warmer. Use the warmer for keeping food warm while the final touches are put to a meal. Turn the control knob counter-clockwise to the 'On' position.

For best results, preheat a covered serving dish for 10 minutes before adding food to it.

Use only heat resistant dishes.

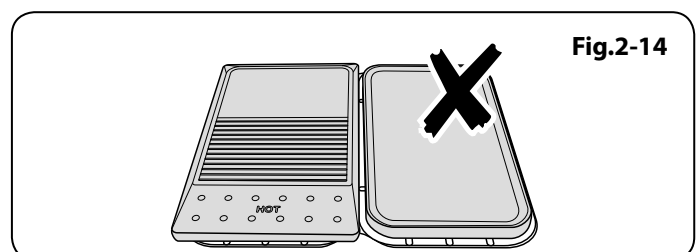
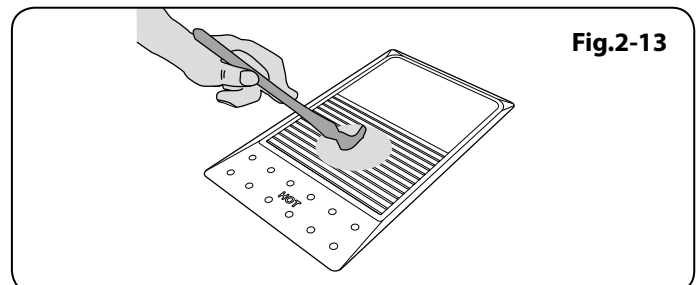
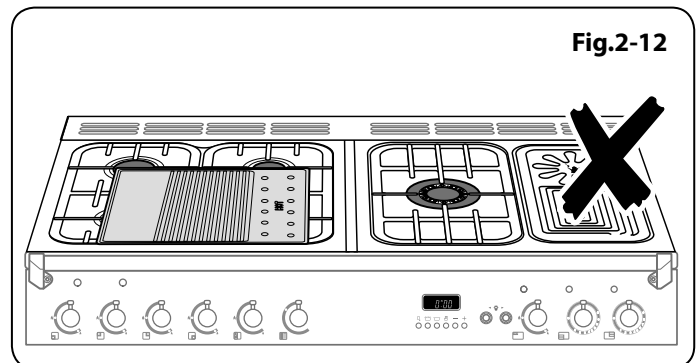
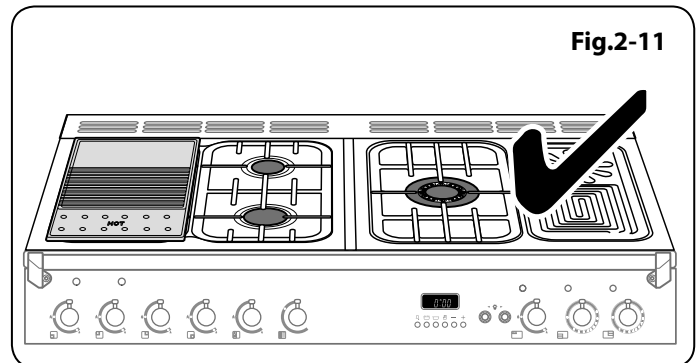
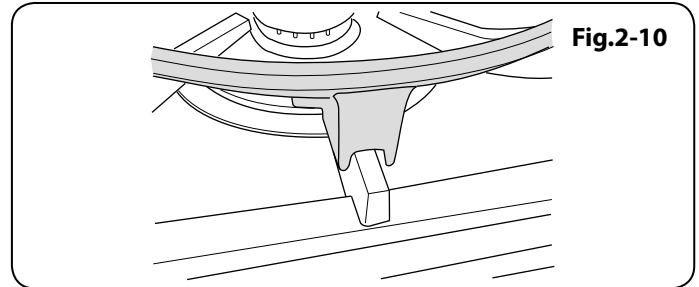
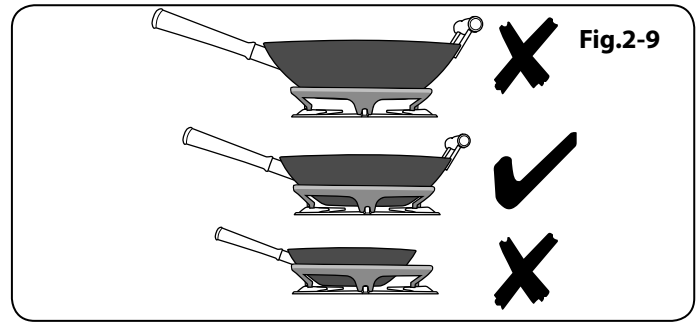

Fig.2-15

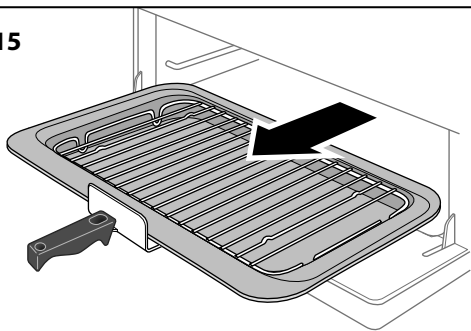

Fig.2-16

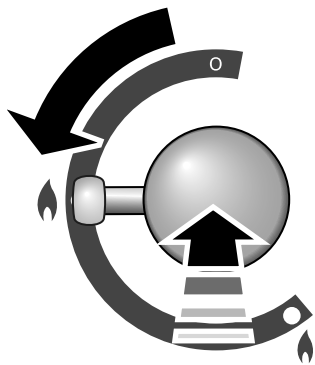

Fig.2-17

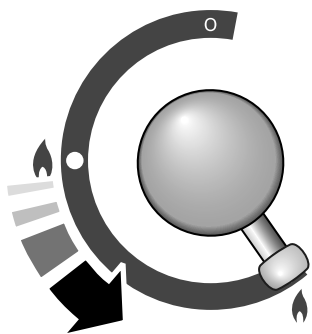
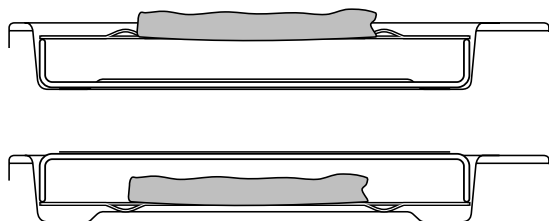

Fig.2-18



The Grill

⚠ Before using the grill for the first time turn on the grill and run for 30 minutes with the grill pan in position, pushed fully back, and the grill door open. Make sure the room is well ventilated to the outside air, by opening windows or turning on a cooker hood for example.

Open the door and, using the handle, pull the grill pan forward (**Fig.2-15**).

The burner does not glow red when in use; food cooks from the heat of the flame. The first time you light the grill there may be a little smoke given off – this is perfectly normal.

Operation

The grill has a special safety device which stops the flow of gas if the flame goes out.

To turn on the grill, press the igniter button and then press and hold the grill control knob to the large flame symbol (🔥) for about 10 seconds (**Fig.2-16**).

To heat the right-hand half, turn the knob counter-clockwise. The neon indicator light by the grill control will come on.

If, when you release the control knob the burner goes out, then the safety device has not held in. Turn the grill control knob to '0' and wait for one minute. Repeat the operation but hold the button and control knob in for slightly longer.

The low position, marked with the small flame symbol, is beyond high, not between high and off (**Fig.2-17**).

For best results, slide the grill pan back into the grill chamber and preheat the appropriate part(s) of the grill for two minutes. The grill trivet can be removed and the food placed on it while you are waiting for the grill to preheat.

⚠ DO NOT leave the grill on for more than a few moments without the grill pan underneath it, otherwise the knobs may become hot.

Once the grill has preheated, slide the grill pan out again. With the trivet back in place with the food on it, slide the pan back into the grill chamber. Make sure that it is pushed right in.

⚠ Accessible parts may be hot when the grill is in use. Young children should be kept away.

The grill pan trivet can be turned over to give two grilling positions (**Fig.2-18**).

Do not leave the grill on for more than a few moments, without the grill pan underneath it.

⚠ Never close the grill door when the grill is on.

The Ovens

The clock must be set to the time of day before the ovens will work. See the following section on 'The Clock' for instructions on setting the time of day.

References to 'left-hand' and 'right-hand' ovens apply as viewed from the front of the appliance.

Both ovens are gas ovens.

- ⚠ Before using for the first time, to dispel manufacturing odours turn the left-hand oven to gas mark 6 and the right-hand oven to 200°C and run for at least an hour.**
To clear the smell make sure the room is well ventilated to the outside air, by opening windows or turning on a cookerhood.
We recommend that people with respiratory problems should vacate the area for this brief period.

Note: Please remember that all cookers vary so temperatures in your new ovens may differ to those in your previous cooker.

The Gas Oven

The gas oven uses our special 'Heatflow' system.

As the oven burner is not hidden under the oven base you will see the burner flames at the back of the oven (**Fig.2-19**). This is perfectly normal.

The oven is protected by a safety cut-off, which reduces the supply of gas to the oven if the flames go out, e.g. and interruption to the mains supply. Initially the gas will burn with a small flame but after approximately one minute the flame will become larger indicating that the oven is full on.

Dishes cooking on the central shelf will cook at the gas mark indicated on the knob (**Fig.2-20**).

Dishes placed above the central position will cook at approximately one gas mark higher; dishes placed below will cook at approximately one gas mark lower (**Fig.2-21**).

You can therefore cook dishes requiring different gas marks at the same time.

'S' (Slow) Cooking

The 'S' setting (**Fig.2-22**) is a very low temperature for slow cooking, overnight or while you are out or at work. The 'S' setting can also be used for keeping food warm.

You can cook on 'S' throughout, or use a 30 minute 'boost' period at gas mark 6 and then 'S' cook.

When roasting joints, poultry or pot roasting, always cook at gas mark 6 for 30 minutes at the beginning of the cooking period.

You can 'S' cook for periods of 6 to 12 hours. This technique is particularly useful if you want to cook a dish overnight or while you are out at work during the day.

- ⚠ Frozen foods must be thoroughly thawed out before 'S' cooking.**

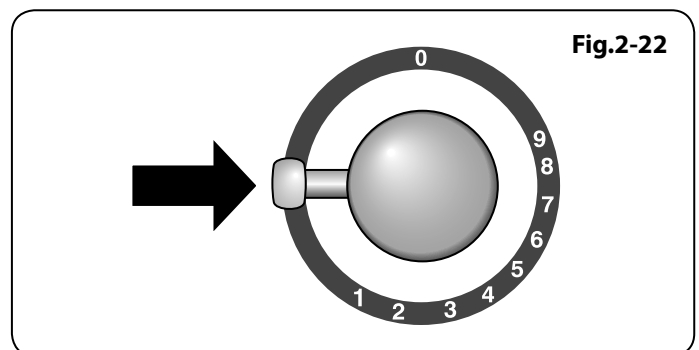
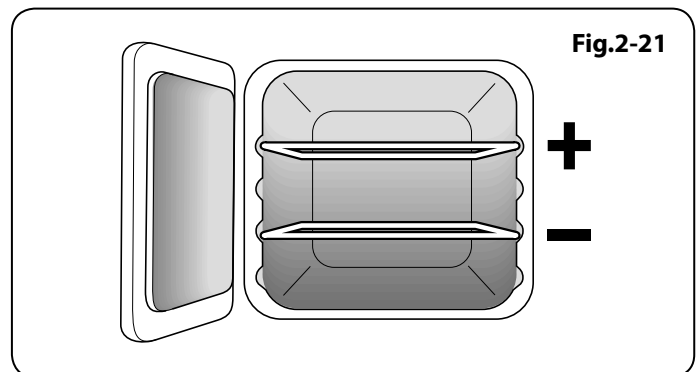
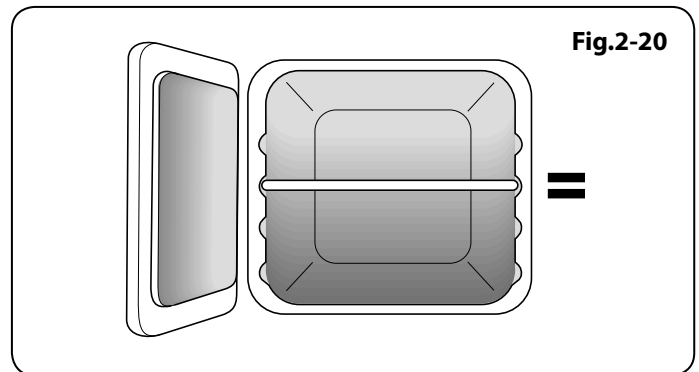
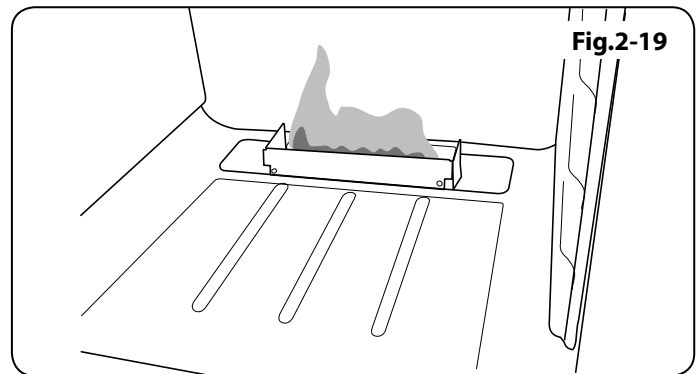

Fig.2-23

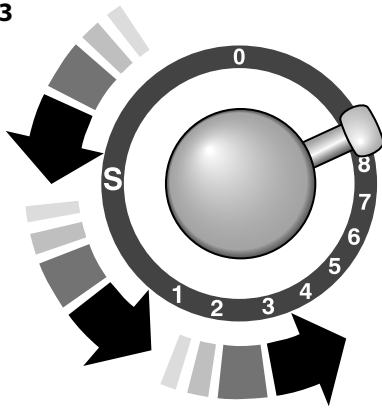
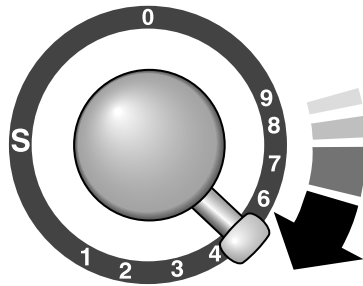

Fig.2-24



⚠ Whole poultry should not be cooked on 'S'. Chicken casseroles are fine.

Casseroles must be brought to boiling point on the hotplate immediately before 'S' cooking.

DO NOT stuff poultry and rolled joints before cooking. The stuffing should be cooked separately. Poultry and pork should be cooked in the top half of the oven, and other meats not lower than shelf position 4.

A roasting joint should be covered with cooking foil or with a roasting bag to reduce shrinkage and retain juices.

Should further browning be necessary, uncover the meat and increase the temperature to gas mark 4 for a short period.

Cut root vegetables into small pieces unless cooking whole, e.g. jacket potatoes.

Cover dishes tightly with a lid or foil to prevent evaporation and transfer of flavour.

Once the oven has been loaded and the 'S' setting is in operation resist the temptation to open the oven door. Heat will be lost and the cooking time extended.

A meat thermometer is recommended for checking that a joint or poultry is sufficiently cooked. Insert the probe through the thickest part of the meat. For the expected temperatures see **Table 2-1**.

Operating the Ovens

Push in and turn the knob controlling the oven to gas mark 9 (**Fig.2-23**). The oven will light automatically.

Turn the oven knob to the desired gas mark (**Fig.2-24**).

Meat		Temperature
Beef	Rare	60 °C / 140 °F
	Medium	71 °C / 160 °F
	Well done	77 °C / 170 °F
Lamb		82° C / 180 °F
Pork	Fresh	88° C / 190 °F
	Cured	77° C / 170 °F
Poultry		90° C / 195 °F
Veal		77° C / 170 °F

Table 2-1

The Clock

You can use the timer to turn the ovens on and off. The clock must be set to the time of day before the ovens will work.

Setting the Time of Day

The 6-button LCD clock is shown in **Fig.2-25**. When the clock is first connected the display flashes (0.00) and () alternately.

Press and hold both the [A] and [B] buttons down (**Fig.2-26**). Now press the [+] button (or the [-] button) until the correct time shows.

Do not forget that it is a 24-hour clock.

If you need to reset the cooker, turn off the power supply and wait for a couple of minutes and start again.

Setting the Minute Minder

Press and hold the [A] button (**Fig.2-27**), and then press the [+] button until the length of time you want to cook for is shown (**Fig.2-28**).

You can check the time remaining by pressing [A]. When the beeper sounds cancel it by pressing [A].

- The 'cook period', which is the length of time you want the oven to cook for.
- The 'stop time', which is the time of day you want the oven to stop cooking.

To Stop the Ovens Automatically

Press and hold the 'stop time' [C] button (**Fig.2-29**) and then press the [+] button (or [-] button) until the required 'stop time' shows (**Fig.2-30**). AUTO will show in the display.

Once the 'stop time' is reached, the beeper sounds. To stop the beep turn the oven control knob to 0 first and then press [D] once; press [D] again to return to manual cooking.

To Start and Stop the Ovens Automatically

Before you set the clock you must have two numbers clearly in mind – the 'cook period' and the 'stop time'.

Note: You cannot set a start time directly – this is set automatically by setting the 'cook period' and the 'stop time'.

Press and hold the [E] button (**Fig.2-31**) and then press the [+] button (or [-] button) until the required 'cook period' shows (**Fig.2-32**).

Now press and hold the [C] button (**Fig.2-33**) and then press the [+] button (or [-] button) until the required 'stop time' shows (**Fig.2-34**). Release the buttons.

AUTO will now show in the display.

Set the oven(s) to the required temperature. When cooking is finished the beeper will sound. Turn the oven knob to the OFF position first, and then press the [D] button once to stop the beep; press it again to return to manual cooking.

If you are out, do not worry about the beeper going off, it stops after a while. When you return, turn the oven knob to 0 first, and then press [D] twice to return to manual cooking.

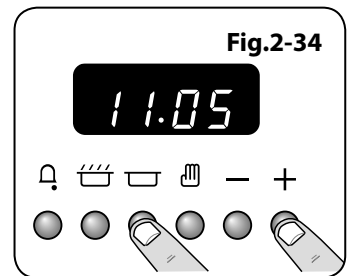
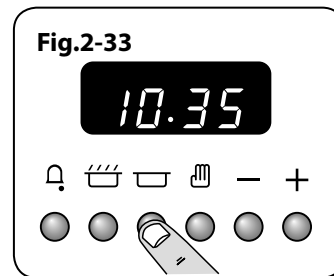
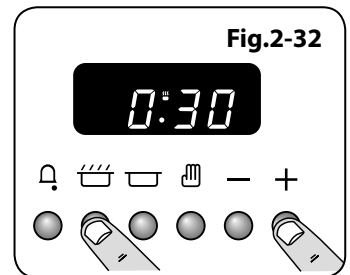
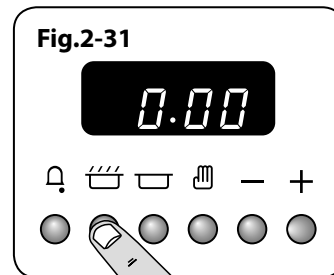
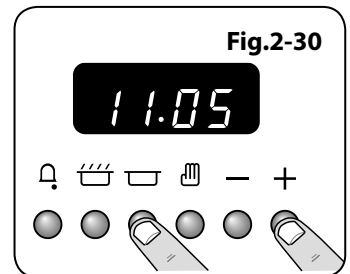
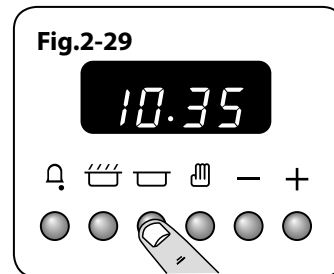
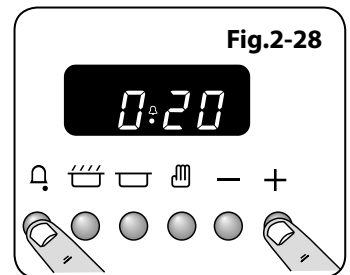
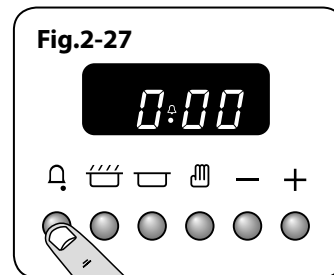
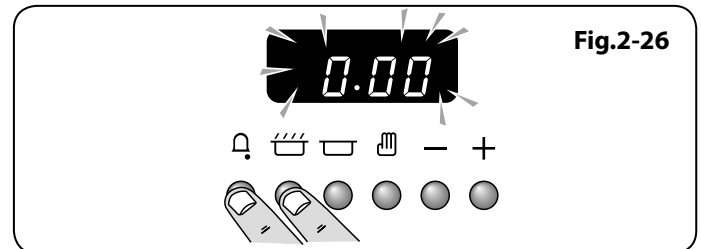
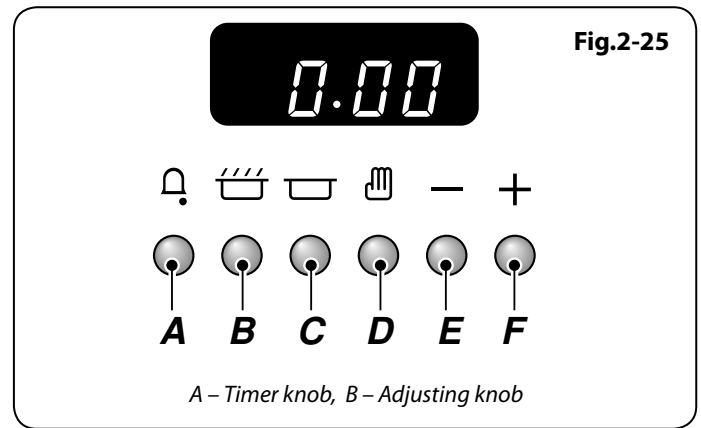

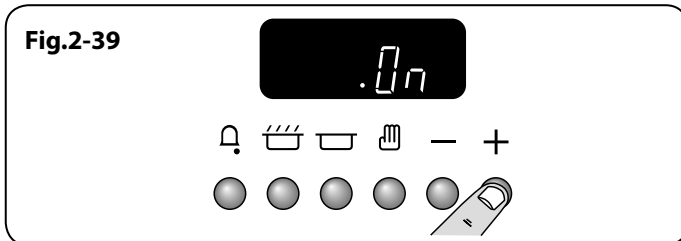
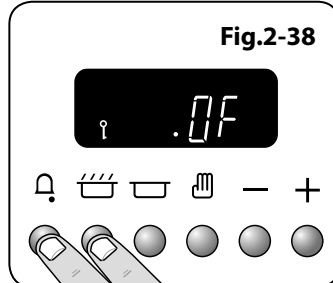
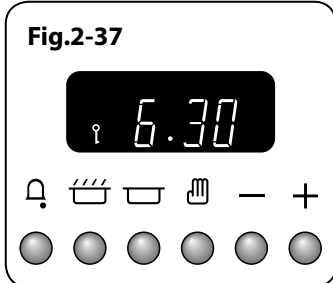
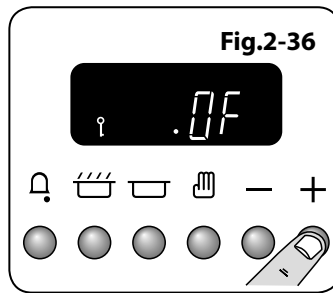
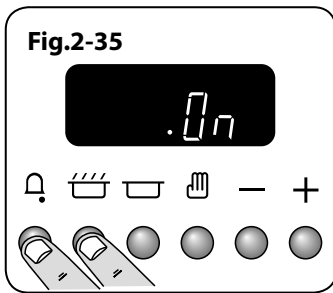

AUTO is Showing, You Want to Reset to Manual Cooking

To return to manual cooking from any automatic setting, the 'cook period' must be cancelled. Press and hold the [☐] button and then press the [-] button until the display reads (0.00).

Press the [☐] button to return to manual cooking.

Key Lock

Activating the key lock will lock the ovens and they will not come on.

To activate the key lock

Make sure that the clock is in manual mode and cancel any active programs.

Hold the Minute Minder [⏰] and Cook period [☐] buttons. When 'On' appears on the display (**Fig.2-35**) press the [+] button once. The key symbol [i] and 'OF' will now show on the display (**Fig.2-36**). Release the buttons.

The ovens are now locked, as confirmed by the display showing the time of day alongside the key symbol (**Fig.2-37**).

To turn off the key lock

Hold the Minute Minder [⏰] and Cook period [☐] buttons. When 'OF' appears on the display (**Fig.2-38**) press the [+] button once. The key symbol [i] will go out and 'On' will show on the display (**Fig.2-39**). Release the buttons.

After a few seconds the display will revert to show the time of day.

The ovens can now be used normally.

Accessories

Oven Shelves

The cooker is supplied with 4 flat shelves (**Fig.2-40**).

The oven shelves can be easily removed and refitted.

Pull the shelf forward until the back of the shelf is stopped by the shelf stop bumps in the oven sides (**Fig.2-41**).

Lift up the front of the shelf so the back of the shelf will pass under the shelf stop and then pull the shelf forward (**Fig.2-42**).

To refit the shelf, line up the shelf with a groove in the oven side and push the shelf back until the ends hit the shelf stop. Lift up the front so the shelf ends clear the shelf stops, and then lower the front so that the shelf is level and push it fully back (**Fig.2-43**).

The Handyrack (Left-hand Oven)

The Handyrack (**Fig.2-44**) fits to the left-hand oven door only. Food cooking on it is easy to attend to, because it is accessible when the door is open.

The maximum weight that can be held by the Handyrack is 5.5 kg (12 lb). It should only be used with the supplied roasting tin, which is designed to fit the Handyrack. Any other vessel could be unstable.

It can be fitted at two different heights. One of the oven shelves must be removed and the other positioned to suit.

When the Handyrack is used in its highest position, other dishes can be cooked on the bottom shelf position or base of the oven.

When the Handyrack is used in its lowest position, other dishes can be cooked on the second shelf position or base of the oven.

To fit the Handyrack, locate one side of it on the door bracket (**Fig.2-45**).

Then spring the other side out to clip it onto the other bracket (**Fig.2-46**).

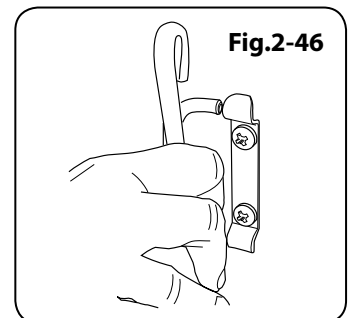
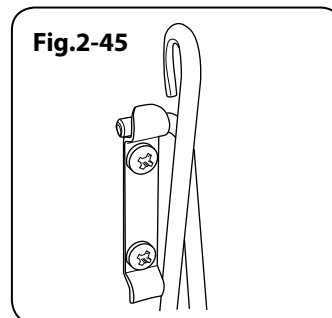
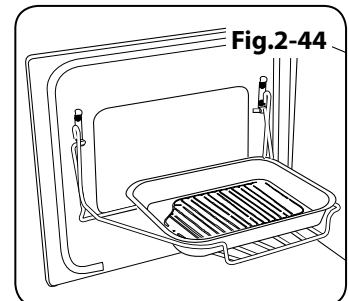
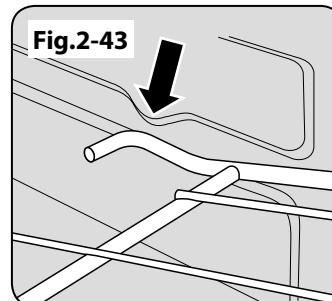
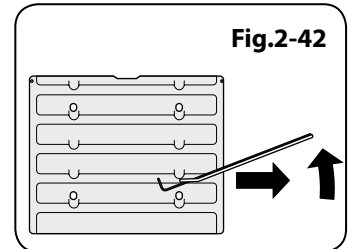
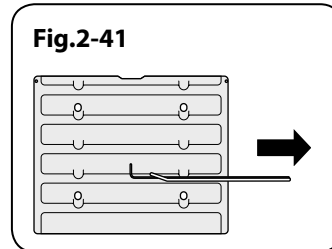
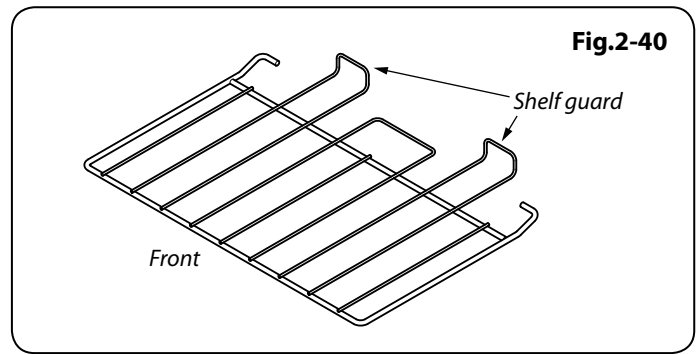
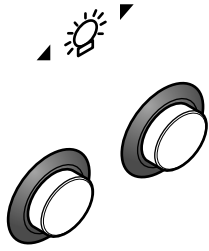

Fig.2-47



Main Oven Light

Press the appropriate button to turn the light on (**Fig.2-47**).

If an oven light fails, turn off the power supply before changing the bulb. See the *'Troubleshooting'* section for details on how to change the bulb.

Storage

The bottom drawer is for storing oven trays and other cooking utensils. It can get very warm, so do not store anything in it that may melt or catch fire.

The drawer can be removed completely by pulling it right out and up (**Fig.2-48**).

Fig.2-48

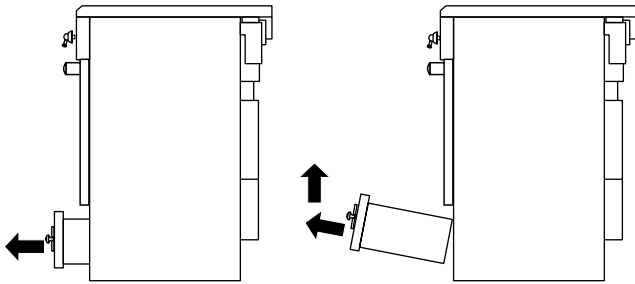

3. Cooking Tips

The wire shelves should always be pushed firmly to the back of the oven.

Baking trays with food cooking on them should be placed level with the front edge of the oven's wire shelves. Other containers should be placed centrally. Keep all trays and containers away from the back of the oven, as overbrowning of the food may occur.

For even browning, the maximum recommended size of a baking tray is 325mm (12¾") by 305mm (12").

When the oven is on, don't leave the door open for longer than necessary, otherwise the knobs may get very hot.

- Always leave a 'fingers width' between dishes on the same shelf. This allows the heat to circulate freely around them.
- To reduce fat splashing when you add vegetables to hot fat around a roast, dry them thoroughly or brush lightly with cooking oil.
- Where dishes may boil and spill over during cooking, place them on a baking tray.

The oven is protected by a safety cut-off, which reduces the supply of gas to the oven if the flames go out, e.g. an interruption to the mains supply.

- Plates can be warmed in the oven on the 'S' setting. The 'S' setting can be used to keep foods hot for 3-4 hours after 'normal' cooking, without drying out or overbrowning.
- The Cook & Clean oven liners (see Cleaning your cooker) work better when fat splashes are avoided. Cover meat when cooking.
- Sufficient heat rises out of the oven while cooking to warm plates in the grill compartment.
- If you want to brown the base of a pastry dish, preheat the baking tray for 15 minutes before placing the dish in the centre of the tray.

4. Cooking Table

The oven control settings and cooking times given in the table below are intended to be used **AS A GUIDE ONLY**. Individual tastes may require the temperature to be altered to provide a preferred result.

Food is cooked at lower temperature in a fan oven than in a conventional oven. When using recipes, reduce the fan oven temperature by 10 °C and the cooking time by 5-10 minutes. The temperature in the fanned oven does not vary with height in the oven so you can use any shelf.

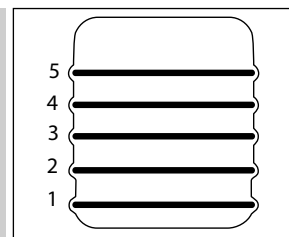

Gas oven shelf positions

Food	Gas Mark	Shelf position	Approximate cooking time		
Meat					
Beef (no bone)	3	3-4	30-35 minutes per 500g +30-35 minutes.	Thoroughly thaw frozen joints before cooking. Meat may be roasted at Mk.7 and the cooking time adjusted accordingly. For stuffed and rolled meats, add approximately 10 minutes per 500g, or cook at Mk.6 for 20 minutes then Mk.3 for the remainder.	
	6	3-4	20-25 minutes per 500g +20-25 minutes.		
Lamb	3	3-4	30-35 minutes per 500g +30-35 minutes.		
	6	3-4	25-30 minutes per 500g +25-30 minutes.		
Pork	3	2-3	35-40 minutes per 500g +35-40 minutes.		
	6	3-4	25-30 minutes per 500g +25-30 minutes.		
Poultry					
Chicken	3	3-4	20-25 minutes per 500g +20-25 minutes.		For stuffed poultry, you could cook at Mk.6 for 20 minutes then Mk.3 for remainder. Do not forget to include the weight of the stuffing. For fresh or frozen prepacked poultry, follow instructions on the pack. Thoroughly thaw frozen poultry before cooking.
	6	3-4	15-20 minutes per 500g +15-20 minutes.		
Turkey	3	4	20 minutes per 500g +20 minutes.		
	6	4	15 minutes per 500g +15 minutes.		
Duck	3	4	25-30 minutes per 500g.		
	6	4	20 minutes per 500g.		
Casserole	1-2	3-4	2-4 hours according to recipe.		
Yorkshire pudding	7	2	Large tins 30-35 minutes; individual 10-20 minutes.		
Fish					
Fillet	5	2	15-20 minutes.		
Whole	5	2	15-20 minutes per 500g.		
Steak	5	2	Steaks according to thickness.		
Cake					
Very rich fruit - Christmas, wedding, etc.	1	4	45-50 minutes per 500g of mixture.	When two tier cooking leave at least one runner space between shelves. Position the baking tray with the front edge along the front of the oven shelf.	
Fruit 180 mm tin	2	4	2-2½ hours.		
Fruit 230 mm tin	2	4	Up to 3½ hours.		
Madeira 180 mm	3	4	80-90 minutes.		
Queen cakes	5	2 & 4 or 3	15-25 minutes.		
Scones	7	2 & 4 or 3	10-15 minutes.		
Victoria sandwich					
180 mm tin	4	2 & 4 or 3	20-30 minutes.		
210 mm tin	4	2 & 4 or 3	30-40 minutes.		
Desserts					
Shortcrust tarts	6	2 & 4	20-30 minutes on a preheated tray.	For even browning the maximum size of baking tray recommended is 340mm x 340mm. This ensures free heat circulation. If cooking a two tier load, the trays should be interchanged approximately halfway though the cooking time.	
Fruit pies	6	2-3	35-45 minutes.		
Tartlets	6	2-3	10-20 minutes according to size.		
Puff pastry	7	2-3-4	20-40 minutes according to size.		
Meringues	'S'	3	2-3 hours.		
Baked egg custard	3	3	45-60 minutes.		
Baked sponge pudding	5	3	40-45 minutes.		
Milk pudding	1-2	3	2 to 3 hours.		
Bread	7	2 & 4	20-30 minutes.		

5. Cleaning Your Cooker

Essential Information

Isolate the electricity supply before carrying out any thorough cleaning. Allow the cooker to cool.

⚠ NEVER use paint solvents, washing soda, caustic cleaners, biological powders, bleach, chlorine based bleach cleaners, coarse abrasives or salt.

⚠ DO NOT mix different cleaning products – they may react together with hazardous results.

All parts of the cooker can be cleaned with hot soapy water – **but take care that no surplus water seeps into the appliance.**

Remember to switch on the electricity supply and reset the clock before re-using the cooker.

Hotplate Burners

The burner heads and caps can be removed for cleaning.

⚠ DO NOT put the burner heads in a dishwasher.

Make sure they are absolutely dry before replacing them.

The Single Ring Burners

When refitting the burner head, make sure that the notch lines up with the electrode or hole in the base. Check that the burner head is level and that the cap is fitted centrally on the burner head (**Fig.5-1**).

The Wok Burner

The wok burner can also be taken apart for cleaning.

When reassembling the wok burner (**Fig.5-2**), turn over the large base ring and find the 'D' shaped area (**Fig.5-3**). Turn the head until the 'D' matches the one on the burner base. Flip the burner over once again and place it on the burner base.

To fit the small inner burner, find the larger electrode notch in the burner rim. Line this up with the white ignition electrode and place the inner burner on the large base ring (**Fig.5-4**).

Now fit the two burner caps, making sure that they are seated properly.

Check the burner ports are not blocked. If a blockage occurs, remove stubborn particles using a piece of fuse wire.

The Wok Cradle

Recommended cleaning materials are hot soapy water, a moistened soap pad, cream cleaner or a nylon scourer.

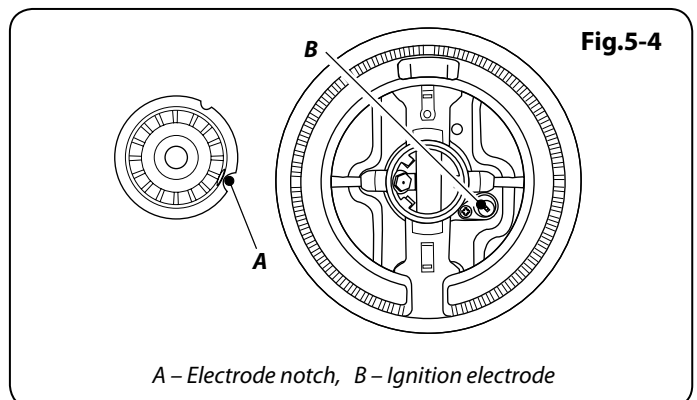
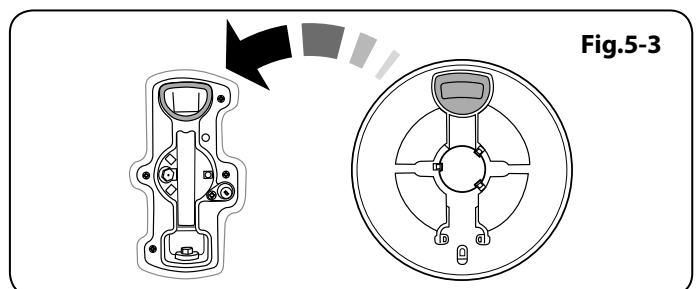
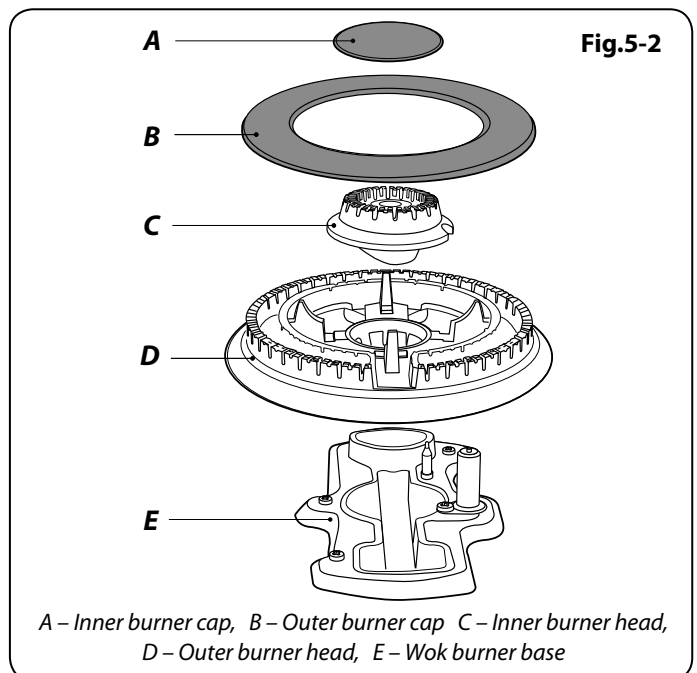
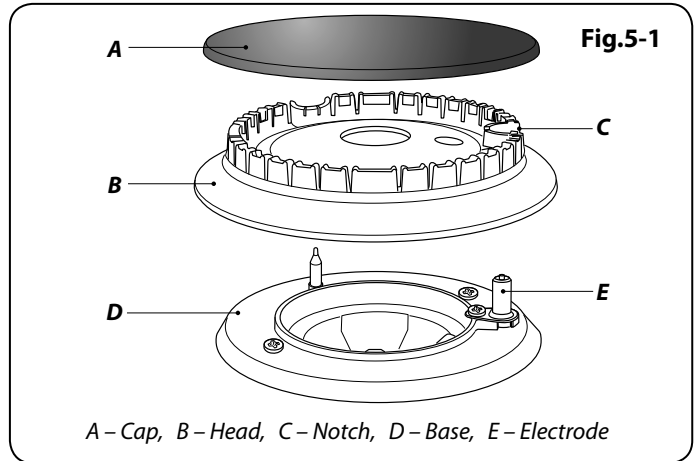

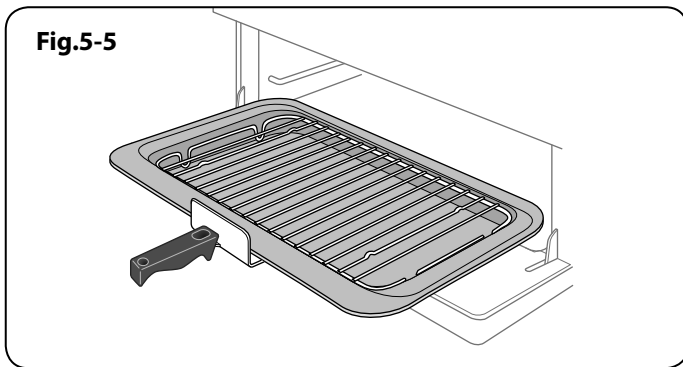

The Griddle

Always clean the griddle after use. Allow it to cool completely before removing. Immerse the griddle plate in hot soapy water. Use a soft cloth or, for stubborn stains, a nylon washing up brush.

Note: If the griddle is washed in a dishwasher then some dishwasher residue may appear on the back. This is normal and will not affect the performance of your griddle.

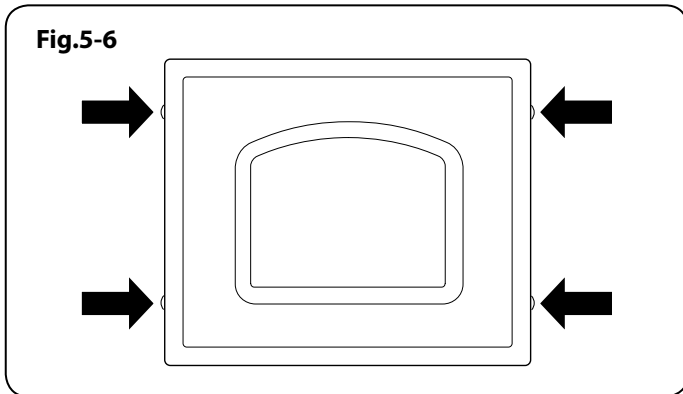

Grill

The face of the grill burner will darken with use – this is perfectly normal. Any fat or grease will burn off. Do not try to clean it – the small holes could get blocked and affect burner performance.

The grill pan can be easily removed for cleaning (**Fig.5-5**).

The grill pan and trivet should be washed in hot soapy water, alternatively, the grill pan can be washed in a dishwasher.

After grilling meats or any foods that soil, leave to soak for a few minutes in the sink immediately after use. Stubborn particles may be removed from the trivet by using a nylon brush.

⚠ Before you remove any of the grill parts for cleaning make sure that they are cool, or use oven gloves.

⚠ DO NOT use any abrasive substances.

Control Panel and Doors

Avoid using any abrasive cleaners including cream cleaners. For best results, use a liquid detergent.

The same cleaner can be used on the doors or alternatively using a soft cloth wrung out in clean hot soapy water – but take care that no surplus water seeps into the appliance.

After cleaning, polish with a dry cloth.

Glass Fronted Door Panels (*some models*)

The oven door front panels can be taken off so that the glass panels can be cleaned. Move the cooker forward to gain access to the sides (see the 'Moving the Cooker' section under 'Installation').

Open the oven door slightly and remove the front panel fixing screws from the door sides, two each side (**Fig.5-6**).

Carefully lift off the outer door panel. The inside face of the glass panels can now be cleaned – take care not to disturb or wet the door insulation.

Note: If the door is triple glazed then the inner two panels are fixed together and should not be separated. After cleaning, carefully refit the outer door panel and replace the side fixing screws.

Ovens

Cleaning is easier if carried out while the oven is still warm. Before cleaning, cover the burner to prevent the burner holes becoming blocked.

The inside of the oven and inner door panel can be cleaned using an approved cleaner (**Table 5-1**).

Take care not to disturb the oven thermostat temperature sensor at the top of the oven opening (**Fig.5-7**).

The enamelled oven burner trim (**Fig.5-8**) can be removed for cleaning.

The oven burner trim hooks onto the front of the oven burner bracket. When refitting make sure that the trim is in the middle of the front of the oven burner bracket (**Fig.5-9**).

'Cook & Clean' Panels

The ovens have panels which have been coated with a special enamel that partly cleans itself. This does not stop all marks on the lining, but helps to reduce the amount of manual cleaning needed.

The 'Cook & Clean' panels work better above gas mark 6 (200°C). If you do most of your cooking below this temperature, occasionally remove the panels and wipe with a lint free cloth and hot soapy water. The panels should then be dried and replaced and the oven heated at gas mark 6 (200°C) for about one hour. This will make sure that the 'Cook & Clean' panels are working effectively.

DO NOT use steel wool, oven cleaning pads, or any other materials that will scratch the surface.

Removing the Main Oven Linings

Some of the lining panels can be removed for cleaning.

If you wish to clean the enamel interior of the oven, you will need to remove the shelves before removing the 'Cook & Clean' panels. You do not have to remove the support brackets to remove the panels. Lift each panels upward and slide forward off the support brackets (**Fig.5-10**).

Once the panels have been removed, the oven enamel interior can be cleaned.

Refit in the reverse order.

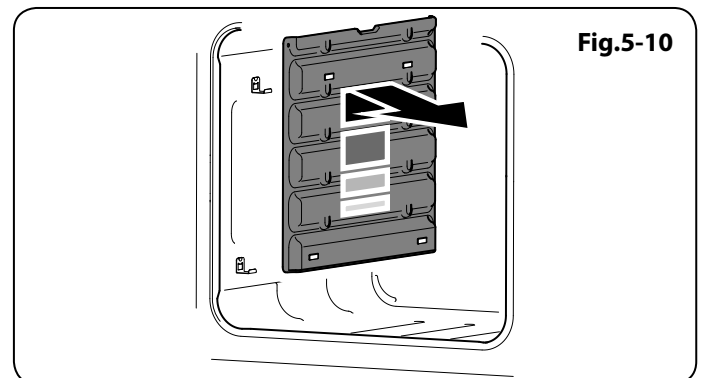
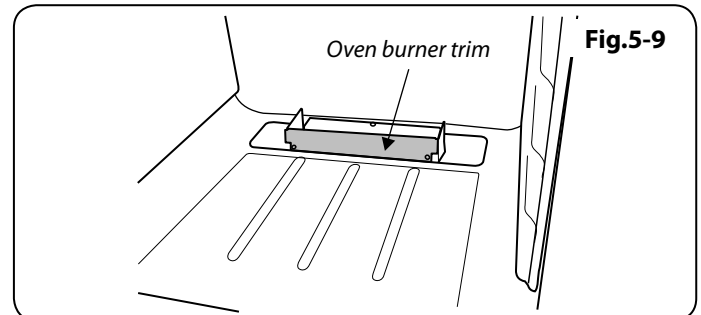
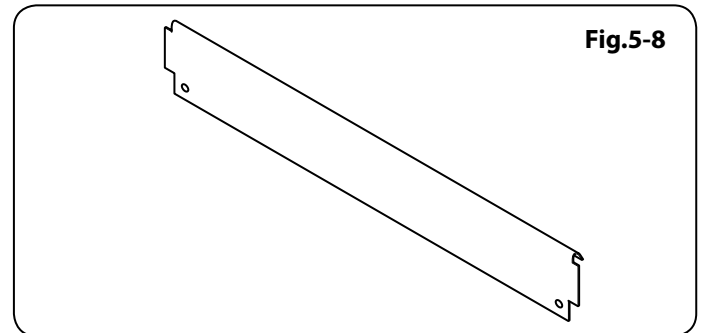
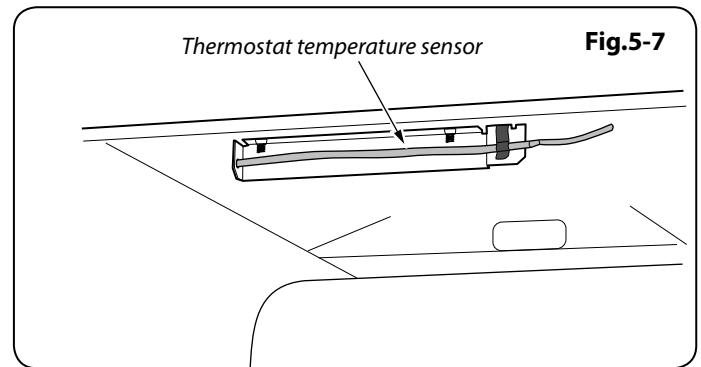

Cleaning Table

Cleaners listed (**Table 5-1**) are available from supermarkets or electrical retailers as stated.

For enamelled surfaces use a cleaner that is approved for use on vitreous enamel.

Regular cleaning is recommended. For easier cleaning, wipe up any spillages immediately.

Hotplate		
Part	Finish	Recommended Cleaning Method
Hob top (including burner heads and caps)	Enamel, stainless steel, aluminium	Hot soapy water, soft cloth. Any stubborn stains remove gently with a nylon scourer.
Griddle plate (some models only)	Non-stick surface	Allow to cool. Wash in hot soapy water. Do not use abrasive cleaners/scourers. Dishwasher.
Warming zone (some models only)	Toughened glass	Hot soapy water, cream cleaner/scourer if necessary.
Outside of cooker		
Part	Finish	Recommended Cleaning Method
Door, Door surround and Storage drawer exterior.	Enamel or paint	Hot soapy water, soft cloth. Any stubborn stains, remove gently with a liquid detergent.
	Stainless steel	E-cloth (<i>electrical retailers</i>) or microfibre all-purpose cloth (<i>supermarket</i>).
Sides and plinth	Painted surface	Hot soapy water, soft cloth.
Splashback/rear grille	Enamel or stainless steel	Hot soapy water, soft cloth. Cream cleaner, with care, if necessary.
Control panel	Paint, enamel or stainless steel	Warm soapy water. Do not use abrasive cleaners on lettering.
Control knobs/handles & trims	Plastic/chrome, copper or lacquered brass	Warm soapy water, soft cloth.
	Brass	Brass polish.
Oven door glass/Glass lid	Toughened glass	Hot soapy water, cream cleaner/scourer if necessary.
Oven and Grill		
Part	Finish	Recommended Cleaning Method
Sides, floor & roof of oven NOT 'COOK & CLEAN' OVEN PANELS (see below)	Enamel	Any proprietary oven cleaner that is suitable for enamel. CAUTION: CORROSIVE/CAUSTIC OVEN CLEANERS: FOLLOW MANUFACTURER'S INSTRUCTIONS. Do not allow contact with the oven elements.
'Cook & Clean' oven panels (some models only)	Special enamel that partly cleans itself	This surface cleans itself at 200°C and above, or the panels can be removed and washed with hot soapy water and a nylon brush (see 'The Ovens' in 'Cleaning Your Cooker').
Oven shelves, Handyrack, Grill trivet, Handygrill rack (some models only)	Chrome	An oven interior cleaner that is suitable for chrome. Soap filled pad. Dishwasher.
Grill Pan/Meat Tin (some models only)	Enamel	Hot soapy water. Soap filled pad. Dishwasher.

Table 5-1

6. Troubleshooting

What cleaning materials are recommended for the cooker?

See the 'Cleaning' section for recommended cleaning materials.

⚠ Never use caustic or abrasive cleaners as these will damage the surface.

If there is an installation problem and I don't get my original installer to come back to fix it who pays?

You do. Service organizations will charge for their call outs if they are correcting work carried out by your original installer. It is in your interest to track down your original installer.

Power failure

In the event of a failure in the electrical supply, remember to reset the clock to make sure that the timed oven continues to operate.

Hotplate ignition or hotplate burners faulty

Is the power on? Is the clock illuminated?

If not, there maybe something wrong with the power supply.

Are the sparker (ignition electrode) or burner slots blocked by debris?

Are the burner trim and caps correctly located? See the section on 'Cleaning'.

Hotplate burners will not light

Make sure that the burner parts have been replaced correctly after wiping or removing for cleaning.

Check that there is not a problem with your gas supply. You can do this by making sure that other gas appliances you may have are working.

Do the burners spark when you push the button?

If not, verify that the power is on by checking that the clock is illuminated.

Grill not cooking properly

Are you using the pan and trivet supplied with the cooker? Is the pan being used on the runners, not the floor of the compartment? Is the grill tray pushed fully back to stop?

Grill ignition faulty

Is the power on?

Is the clock illuminated?

If not there maybe something wrong with the power supply.

The knobs get hot when I use the oven or the grill. Can I avoid this?

Yes, this is caused by heat rising from the oven or the grill, and heating them up. Do not leave the oven door open.

Make sure that the grill pan is pushed right back to the 'back stop' when grilling.

Always grill with the grill compartment door open.

An oven fan is noisy

The note of the oven fan may change as the oven heats up – this is perfectly normal.

Steam is coming from the oven

When cooking foods with high water content (e.g. oven fries) there may be some steam visible at the rear grille.

Take care when opening the oven door, as there may be a momentary puff of steam when the oven door is opened. Stand well back and allow any steam to disperse.

Food is cooking too slowly, too quickly, or burning

Cooking times may differ from your previous oven.

Check that you are using the recommended temperatures and shelf positions – see the oven cooking guide. The oven control settings and cooking times are intended to be used **only** as a guide.

Individual tastes may require the temperature to be altered either way, to get the results you want.

The oven is not cooking evenly

Do not use a baking tray with dimensions larger than those specified in the section on 'General Oven Tips'.

If you are cooking a large item, be prepared to turn it round during cooking.

If two shelves are used, check that space has been left for the heat to circulate. When a baking tray is put into the oven, make sure that it is placed centrally on the shelf.

Check that the door seal is not damaged and that the door catch is adjusted so that the door is held firmly against the seal.

A dish of water when placed on the shelf should be the same depth all over. (For example, if it is deeper at the back, then the back of the cooker should be raised up or the front lowered.) If the cooker is not level arrange for your supplier to level it for you.

Fig.6-1

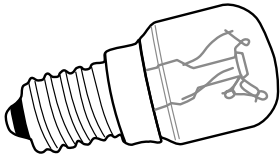

Fig.6-2

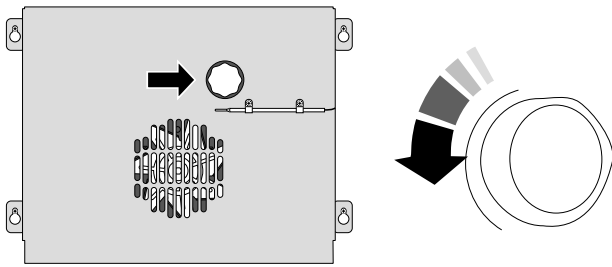
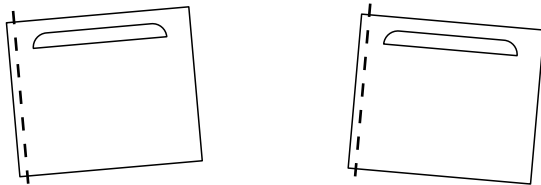
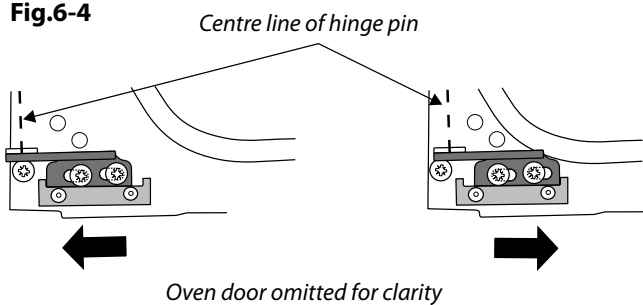

Fig.6-3



Effect of hinge adjustment – exaggerated for clarity

Fig.6-4



Oven door omitted for clarity

Oven not coming on

Is the power on? Is the clock illuminated? If not, there may be something wrong with the power supply.

Is the cooker supply on at the isolator switch?

Has the time of day been set?

Is the key symbol [🔒] showing in the display to signify that the oven is locked? See the 'Clock' section of the instructions for more information on the key lock feature.

The timed oven is not coming on when automatic cooking

Has the oven knob been left in the OFF position by mistake?

Is the oven locked (*see above*)?

Oven temperature getting hotter as the cooker gets older

If turning the temperature down using the oven control knob has not worked, or has only worked for a short time, then you may need a new thermostat. This should be fitted by a service person.

An oven light is not working

The bulb has probably burnt out. You can buy a replacement bulb (which is not covered under the warranty) from a good electrical shop. Ask for a 15W – 230V lamp, FOR OVENS. It must be a special bulb, heat resistant to 300°C (**Fig.6-1**).

Turn off the power at the circuit breaker.

Before removing the existing bulb, turn off the power supply and make sure that the oven is cool. Open the oven door and remove the oven shelves.

Unscrew the bulb cover by turning counter-clockwise. It may be very stiff (**Fig.6-2**).

Taking care to protect your fingers with a glove in case the bulb should shatter, unscrew the old bulb.

Screw in the new bulb; screw back the bulb cover. Turn on the circuit breaker and check that the bulb now lights.

The oven door is misaligned

The bottom hinge of either oven door can be adjusted to alter the angle of the door (**Fig.6-3**). Loosen the bottom hinge fixing screws and use the notch and a flat bladed screwdriver to move the position of the hinge to set the hinge position (**Fig.6-4**).

Retighten the hinge screws.

INSTALLATION

Check the appliance is electrically safe and gas sound when you have finished.







7. Installation

Dear Installer

Before you start your installation, please complete the details below, so that, if your customer has a problem relating to your installation, they will be able to contact you easily.

Installer's Name
Installer's Company
Installer's Telephone Number
Appliance Serial Number

Safety Requirements and Regulations

-  **This cooker must be installed in accordance with the relevant instructions in this booklet, with the relevant national and local regulations, and with the local gas and electricity supply companies' requirements.**
-  **This cooker is a Class 2 Subclass 1 appliance.**
-  **Before installation, make sure that the cooker is suitable for your gas type and supply voltage. See the data badge.**
-  **The appliance must be installed in accordance with the regulations in force and only in a well-ventilated space.**
-  **Read the instructions before installing or using this appliance.**
-  **In your own interest and that of safety, it is law that all gas appliances be installed by competent persons. Failure to install the appliance correctly could invalidate any warranty or liability claims and lead to prosecution.**

In the UK the cooker must be installed in accordance with:

- **All relevant British Standards / Codes of Practice, in particular BS 5440 Part 2.**
- **For Natural Gas – BS 6172 and BS 6891.**
- **For LP Gas – BS 5482-1 (when the installation is in a permanent dwelling), BS 5482-2 (when the installation is in a caravan or other non-permanent dwelling), or BS 5482-3 (when the installation is in a boat).**
- **The Gas Safety (Installation and Use) regulations.**
- **The relevant Building / IEE regulations.**

In the Republic of Ireland the cooker must be installed in accordance with:

The installation must be carried out by a competent person and installed in accordance with the current edition of IS 813 "Domestic Gas Installations", the current Building Regulations and reference should be made to the current ETCI rules for electrical installation.

Provision of Ventilation

This appliance is not connected to a combustion products evacuation device. Particular attention shall be given to the relevant requirements regarding ventilation.

All rooms require a window that can be opened, or equivalent, while some rooms require a permanent vent in addition to the window.

In the UK

The room containing the cooker should have an air supply in accordance with BS 5440 Part 2. All rooms require an openable window or equivalent, while some rooms require a permanent vent in addition to the openable window. The cooker should not be installed in a bedsitting room with volume less than 20 m³. If it is installed in a room of volume less than 5 m³ an air vent of effective area 100 cm² is required; if it is installed in a room of volume between 5 m³ and 10 m³, an air vent of effective area 50 cm² is required; while if the volume exceeds 11 m³, no air vent is required.

If there are other fuel burning appliances in the same room, BS 5440 Part 2 should be consulted to determine the requisite air vent requirements.

In the Republic of Ireland

Reference should be made to the current edition of IS 813, which makes clear the conditions that must be met to demonstrate that sufficient ventilation is available.

INSTALLATION

Check the appliance is electrically safe and gas sound when you have finished.

Location of Cooker

The cooker may be installed in a kitchen/kitchen diner but NOT in a room containing a bath or shower.

This appliance is designed for domestic cooking only. Use for any other purpose could invalidate any warranty or liability claim.

Note: An appliance for use on LPG must not be installed in a room or internal space below ground level, e.g. in a basement.

You will need the following equipment to complete the cooker installation satisfactorily:

- Stability bracket: If the cooker is to be supplied with gas through a flexible hose, a stability bracket or chain MUST be fitted.
These are not supplied with the cooker but are available at most builders' merchants.
- Gas pressure tester/manometer.
- Flexible gas hose: Must be in accordance with the relevant standards.
- Multimeter: For electrical checks.

You will also need the following tools:

1. Electric drill
2. Masonry drill bit (only required if fitting the cooker on a stone or concrete floor)
3. Wall plugs (only required if fitting the cooker on a stone or concrete floor)
4. Steel tape measure
5. Cross head screwdriver
6. Flat head screwdriver
7. Spirit level
8. Pencil
9. Adjustable spanner
10. Allen keys (for Classic – supplied)
11. Screws for fitting stability bracket
12. 13 mm spanner (or socket wrench)

Checking the Parts:

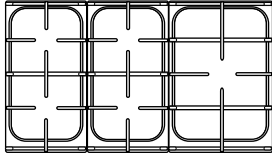
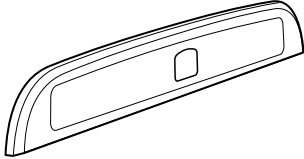
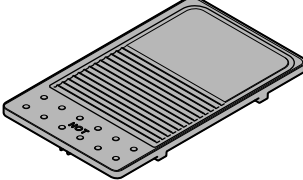
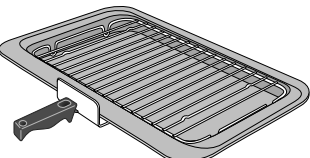
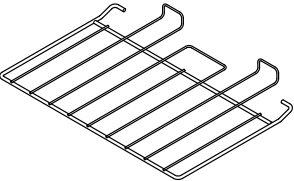
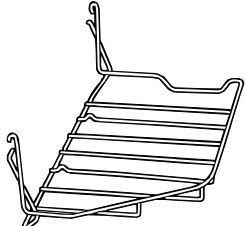
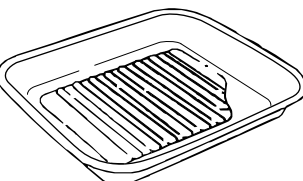
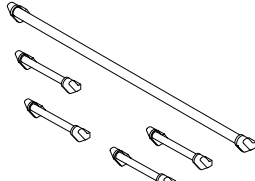
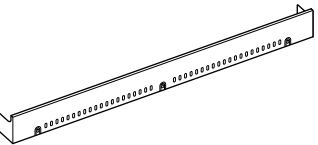
<i>3 pan supports</i>	<i>Splashback (Classic only)</i>
	
<i>Griddle</i>	<i>Grill pan & trivet</i>
	
<i>4 flat shelves</i>	<i>Handyrack</i>
	
<i>Roasting tin</i>	<i>Handles (Classic only)</i>
	
<i>Plinth</i>	
	

INSTALLATION

Check the appliance is electrically safe and gas sound when you have finished.

Positioning The Cooker

Fig.7-1 and Fig.7-2 show the minimum recommended distance from the cooker to nearby surfaces.

The cooker should not be placed on a base.

Above hotplate surround should be level with, or above, any adjacent work surface.

A gap of 75 mm should be left between each side of the cooker **ABOVE** the hotplate level and any adjacent vertical surface.

For non-combustible surfaces (such as unpainted metal or ceramic tiles), this can be reduced to 25 mm.

A minimum space of 650 mm is required between the top of the hotplate and a horizontal combustible surface.

**Any cookerhood should be installed in accordance with the hood manufacturer's instructions.*

***Any splashback must be fitted in accordance with the manufacturers instructions. Allowance should be made for the additional height of the flue trim, which is fitted to the cooker hob.*

Surfaces of furniture and walls at the sides and rear of the appliance should be heat, splash and steam resistant. Certain types of vinyl or laminate kitchen furniture are particularly prone to heat damage and discolouration.

We cannot accept responsibility for damage caused by normal use of the cooker to any material that de-laminates or discolours at temperatures less than 65°C above room temperature.

We recommend a gap of 1110 mm between units to allow for moving the cooker. Do not box the cooker in – it must be possible to move the cooker in and out for cleaning and servicing.

A clearance of 130 mm is required if the cooker is near a corner of the kitchen to allow the oven doors to open (Fig.7-3). The actual opening of the doors is slightly less but this allows for some protection of your hand as you open the door.

Moving the Cooker

⚠ On no account try and move the cooker while it is plugged into the electricity supply.

⚠ The cooker is very heavy, so take great care.

We recommend that two people manoeuvre the cooker. Make sure that the floor covering is firmly fixed, or removed, to prevent it being disturbed when moving the cooker around.

To help you, there are two levelling rollers at the back, and two screw-down levelling feet at the front.

Remove the polystyrene base pack. From the front, tilt the cooker forward and remove the front half of the polystyrene base (Fig.7-4). Repeat from the back and remove the rear half of the polystyrene base.

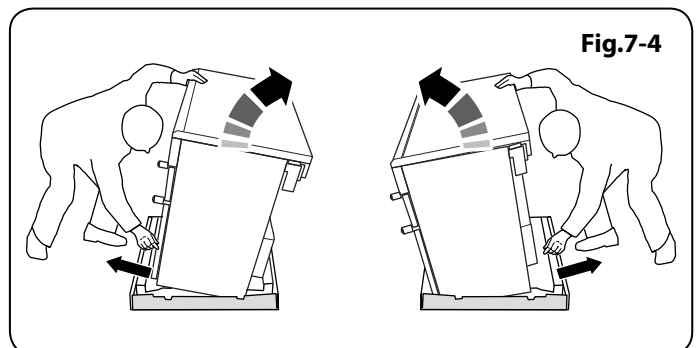
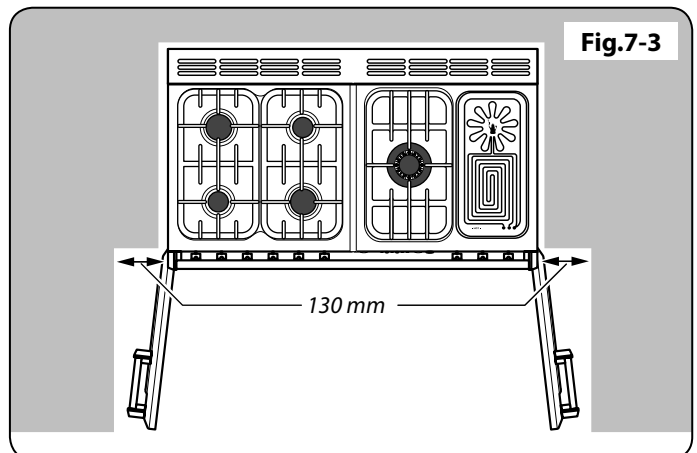
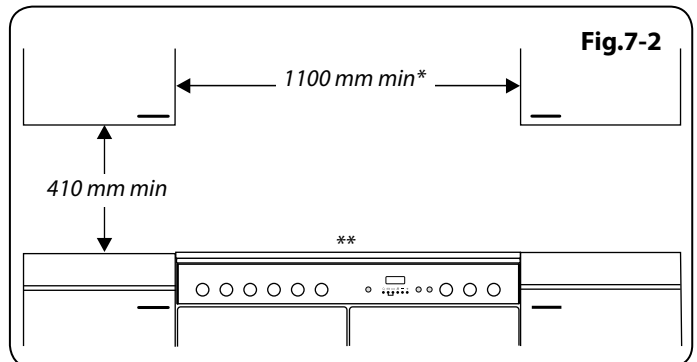
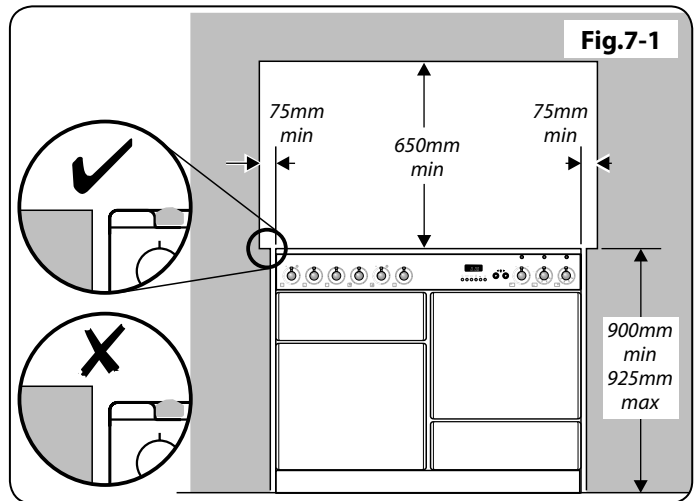

INSTALLATION

Check the appliance is electrically safe and gas sound when you have finished.

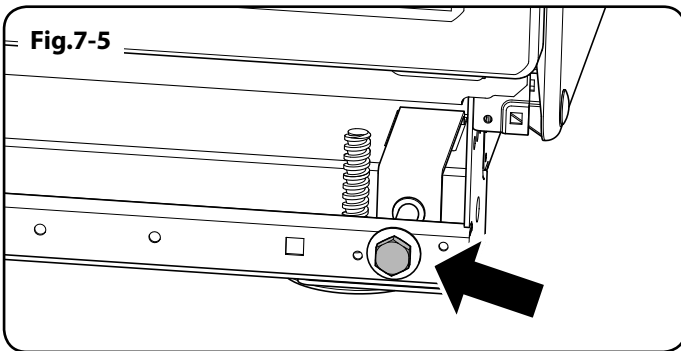

Lowering the Two Rear Rollers

To adjust the height of the rear of the cooker, first fit a 13 mm spanner or socket wrench onto the hexagonal adjusting nut (**Fig.7-5**). Rotate the nut – clockwise to raise – counter-clockwise to lower.

Make 10 complete (360°) turns clockwise.

Make sure you lower BOTH REAR ROLLERS.

Completing the Move

Unfold the rear edge of the cardboard base tray. Open the grill door and right-hand oven door so that you can get a good grip on the bottom of the fascia panel as you move the oven (**Fig.7-6**).

Carefully push the cooker backwards off the cardboard base. Remove the base tray.

Position the cooker close to its final position, leaving just enough space to get behind it.

▲ DO NOT use the door handles or control knobs to manoeuvre the cooker.

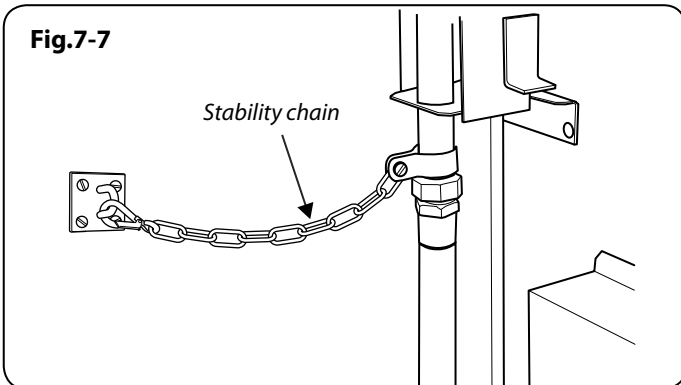
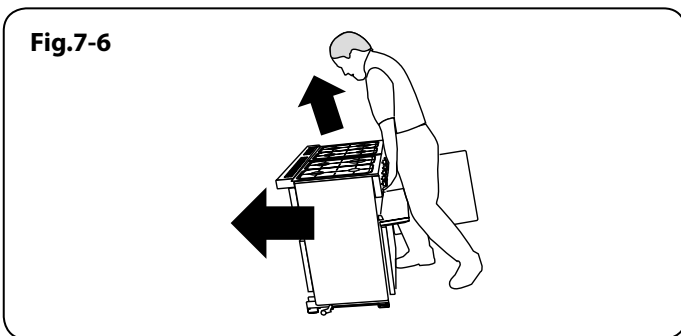

Fitting the Stability Bracket or Chain

Unless otherwise stated, a cooker using a flexible gas connector must be secured with a suitable stability device.

Suitable stability devices are shown in **Fig.7-7**, **Fig.7-8** and **Fig.7-9**.

If you are using a stability chain (**Fig.7-7**) then the chain should be kept as short as is practicable and fixed firmly to the rear of the cooker.

If you are using a stability bracket (**Fig.7-8** and **Fig.7-9**), then adjust the bracket to give the smallest practicable clearance between the bracket and the engagement slot in the rear of the cooker.

Fit the bracket so that it engages as far as possible over the chassis of the cooker.

Repositioning the Cooker Following Connection

If you need to move the cooker once it has been connected then you need to unplug it and, having gripped under the fascia panel and lifted the front of the cooker slightly (**Fig.7-6**); you need to check behind the cooker to make sure that the gas hose is not caught.

As you progress, make sure that both the electricity cable and gas hose always have sufficient slack to allow the cooker to move.

With a stability chain fitted, release it as you ease the cooker out. Do not forget to refit it when you replace the cooker.

When you replace the cooker, again check behind to make sure that the electricity cable and gas hose are not caught or trapped.

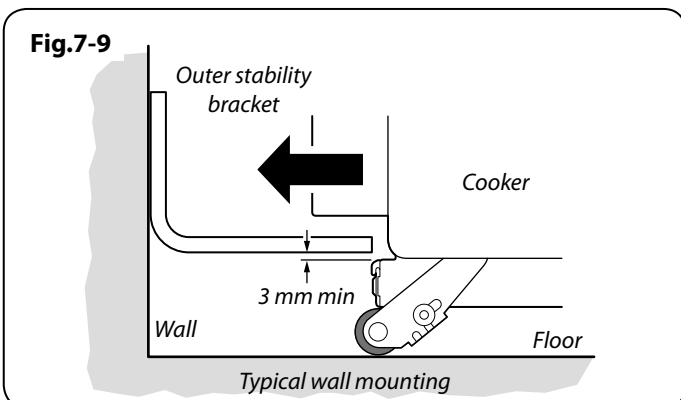
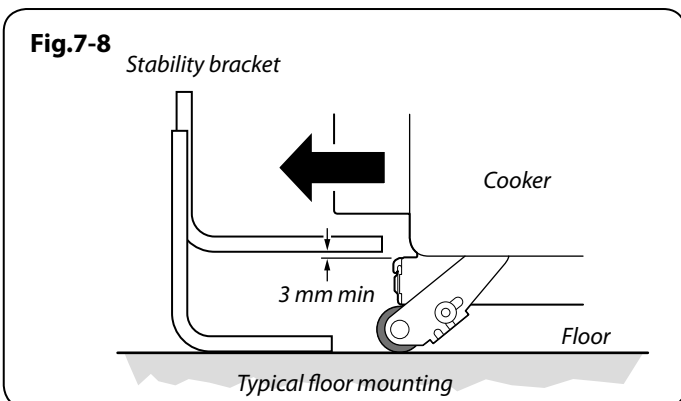

INSTALLATION

Check the appliance is electrically safe and gas sound when you have finished.

Levelling the Cooker

It is recommended that you use a spirit level on a shelf in one of the ovens to check for level.

Place the cooker in its intended position. Take care not to twist it within the gap between the kitchen units as damage may occur to the cooker or units.

The front feet and rear rollers can be adjusted to level the cooker.

To adjust the height of the rear of the cooker use a 13 mm spanner or socket wrench to turn the hexagonal adjusting nuts at the front bottom corners of the cooker.

To set the front, turn the feet bases to raise or lower.

Fitting the Oven Burner Trim

The oven burner has an enamel burner trim. To fit the trim, simply hook it over the front of the oven burner bracket (**Fig.7-11**). Make sure that the burner trim is central to the oven burner bracket.

Gas Connection

This must be in accordance with the relevant standards.

The flexible hose (not supplied with the cooker) must be in accordance with the relevant standards. Hoses may be purchased at most builders' merchants.

The gas supply needs to terminate with a down-facing bayonet.

The connector is located just below the hotplate level at the rear of the cooker. If in doubt contact your supplier.

The rear cover boxes limit the position of the supply point.

Because the height of the cooker can be adjusted and each connection is different, it is difficult to give precise dimensions.

Although a 900 mm hose can be used, a 1250 mm hose will allow slightly more flexibility in the positioning of the bayonet and make moving the cooker easier.

The hose should be fitted so that both inlet and outlet connections are vertical so that the hose hangs downwards in a 'U' shape.

Ideally the hose supply connection should be within the shaded area 'A' (**Fig.7-10**).

For Natural Gas, the flexible hose must be in accordance with BS 669. For LP Gas, it should be capable of 50 mbar pressure, 70 °C temperature rise, and carry a red stripe, band or label. If in doubt contact your supplier.

Screw connect the threaded end of the hose into the gas inlet.

After completing the gas connection, make sure that the cooker is gas sound with a pressure test.

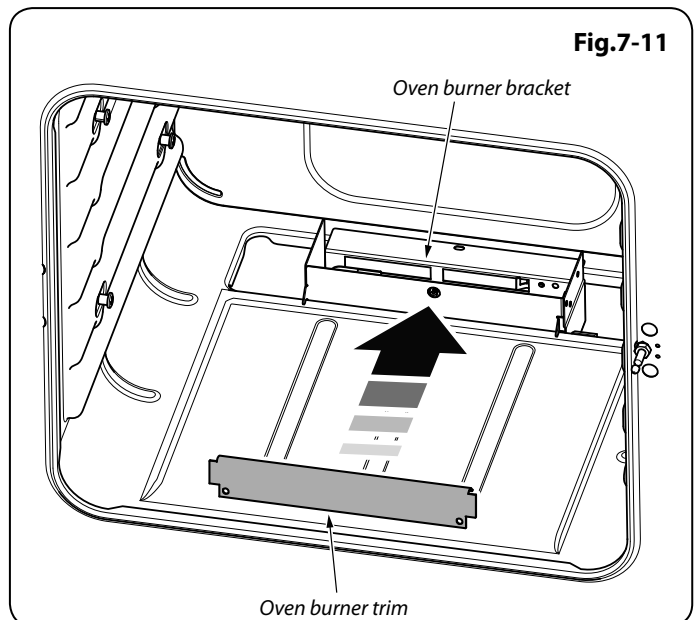
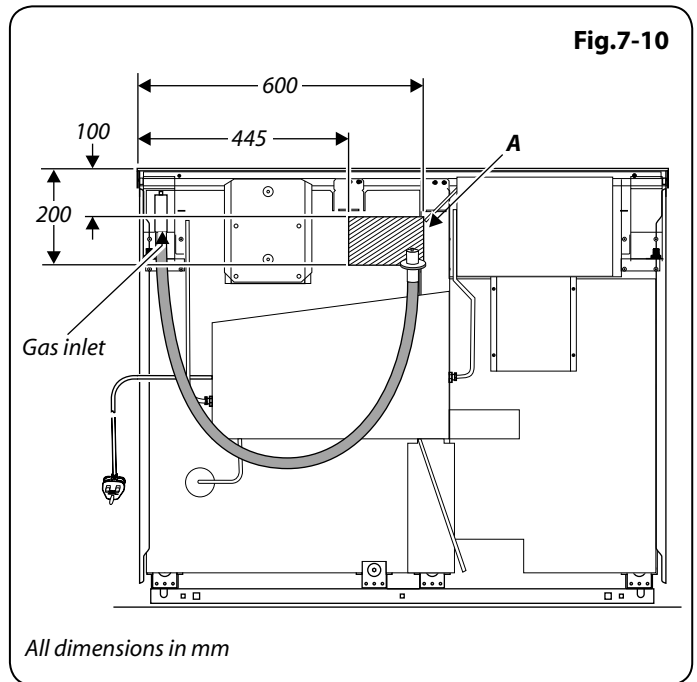

INSTALLATION

Check the appliance is electrically safe and gas sound when you have finished.

Fig.7-12

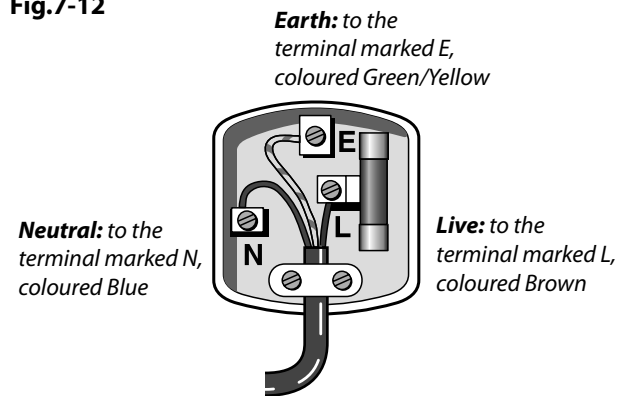

Pressure Testing

The gas pressure can be measured at one of the hotplate burner injectors (not the wok burner).

Lift off a burner head. Fit the pressure gauge to the injector. Turn on and light one of the other hotplate burners.

Turn on the control knob for the burner with the pressure gauge fitted to let gas through.

See the data badge for test pressures.

Turn off the burners. Make sure that you reassemble the burner top in the correct way on the burner body.

Electrical Connection

The cooker must be installed by a qualified electrician, in accordance with all relevant British Standards/Codes of Practice (in particular BS 7671), or with the relevant national and local regulations.

⚠ WARNING: THIS APPLIANCE MUST BE EARTHED.

All external wiring must comply with the IEE Regulations for the Electrical Equipment of Buildings. Connection to the electrical supply can be made with either a plug and socket or be permanently wired via a double-pole switch. The cooker is supplied with a 3-core cable 2 m long. If a replacement cable is fitted it must be 250V high temperature PVC (85 °C), 1 mm².

Should the plug not fit the socket in your home, it should be removed and replaced with a suitable plug.

Note: If the plug is fitted is not suitable, it must be cut off and disposed of properly. To avoid the risk of electrocution, the plug must not be left where children might find it and plug it into a supply socket.

Three pin plugs to BS 1363 with a capacity of not less than 13 A must be used and fitted with a 13 amp fuse 'ASTA' approved to BS 1362.

You **MUST** refit the cover after replacing the fuse. If the cover is lost, the plug **MUST NOT** be used until a replacement cover has been obtained from your supplier. The colour of the correct fuse carrier is that of the coloured insert in the base of the fuse recess, or stated elsewhere on the plug. Always state this colour when ordering a replacement fuse carrier.

IMPORTANT: The wires in the mains lead are coloured in accordance with the following code (Fig.7-12):

Green and yellow:	EARTH
Blue:	NEUTRAL
Brown:	LIVE

INSTALLATION

Check the appliance is electrically safe and gas sound when you have finished.

Final Checks

Hotplate Check

Check each burner in turn (refer to the 'Hotplate Burners' section at the front of the instructions).

Grill Check

Turn on the grill and check that the grill heats up.

Oven Check

Set the clock as described earlier in the instructions, and then turn on the ovens. Check that the oven burners light and start to heat up.

Note: The oven light bulb is not included in the guarantee.

Turn off the ovens.

Final Fitting

Fitting the Handles and Handrail (Classic only)

Remove the 4 mm Allen screws from the doors (**Fig.7-13**). Fit the door handles and secure using the 4 mm screws.

⚠ The handles should be above the fixings.

Remove the 4 mm Allen screws from the top corners of the fascia (**Fig.7-14**). Fit the front handrail in position and secure using the 4 mm screws.

Fitting the Plinth

Loosen the three screws along the front bottom edge of the cooker. Hook the central keyhole over the central screw. Twist and fit each end keyhole over their respective screws. Tighten the fixing screws (**Fig.7-15**).

Fitting the Splashback (Classic only)

Position the splashback on the rear of the hotplate and secure with the screws supplied.

Customer Care

Installer: Please complete your details in this guide, inform the user how to operate the cooker and hand over the instructions.

Thank you.

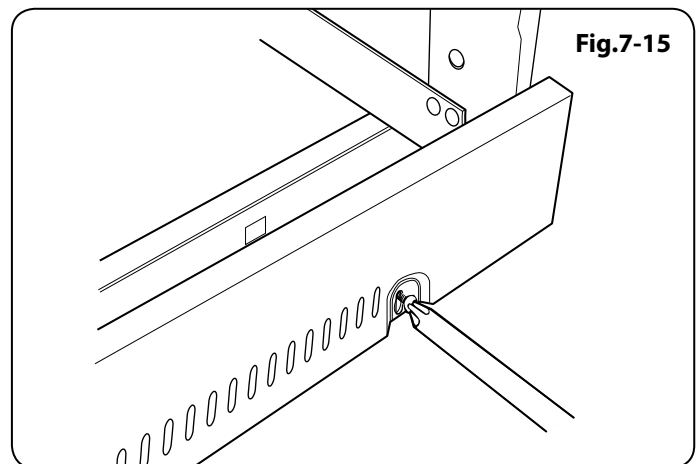
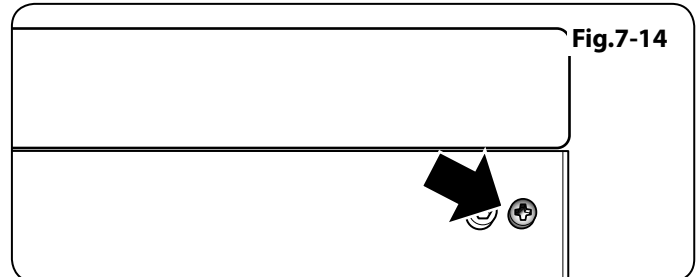

8. Circuit Diagram

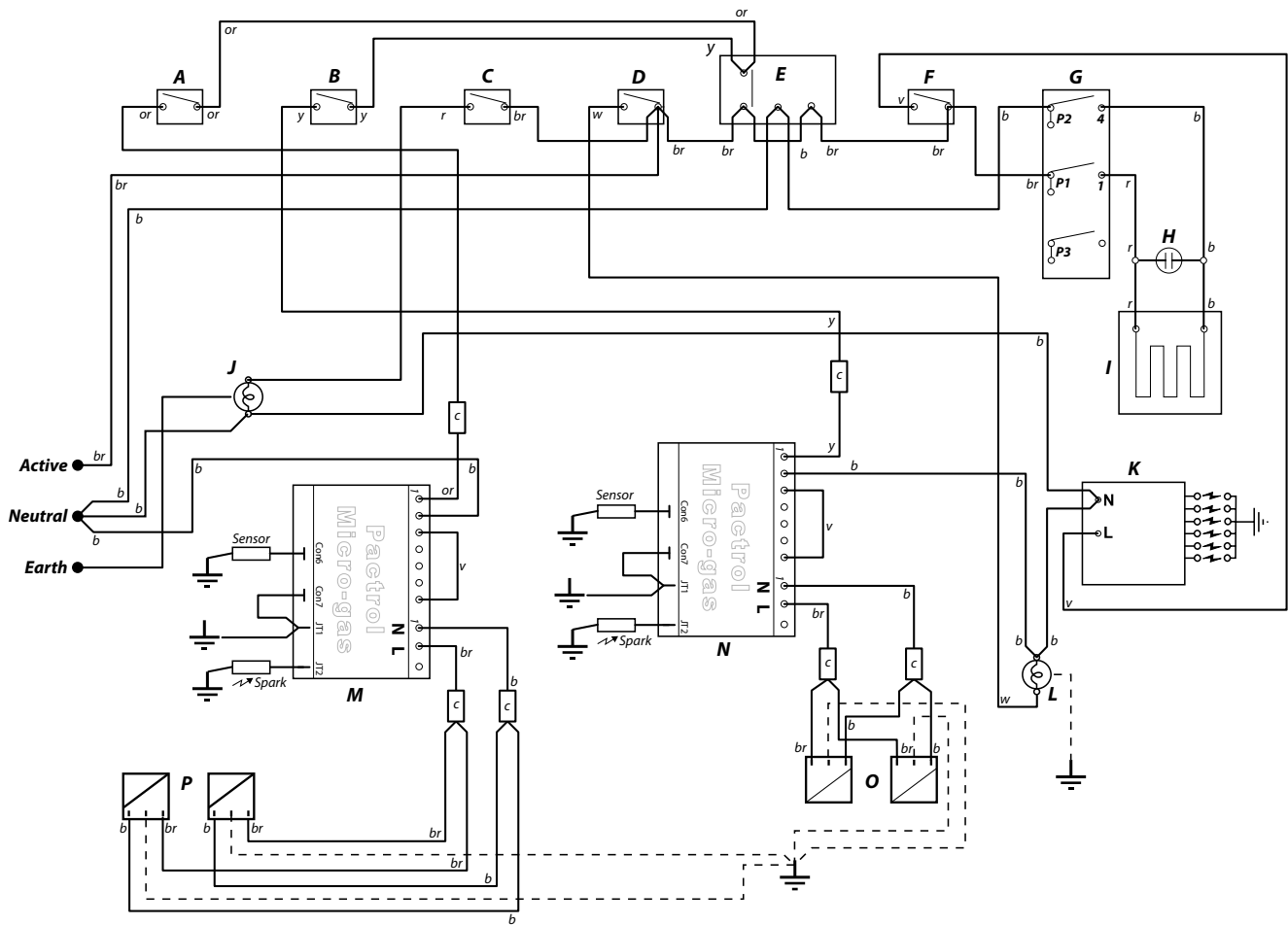

Key

The connections shown in the circuit diagram are for single-phase. The ratings are for 230V 50Hz.

Key	Description
A	Right-hand oven stat switch
B	Left-hand oven stat switch
C	Right-hand oven light switch
D	Left-hand oven light switch
E	Clock
F	Ignition switch
G	Warmer switch
H	Neon
I	Warmer
J	Right-hand oven light bulb
K	Spark generator
L	Light-hand oven light bulb
M	Flame safeguard unit
N	Flame safeguard unit
O	Solenoid assembly
P	Solenoid assembly

Code	Colour
b	Blue
br	Brown
bk	Black
or	Orange
r	Red
v	Violet
w	White
y	Yellow
g/y	Green/Yellow
gr	Grey

9. Technical Data

This cooker is designed for use on either:

- Natural gas (Cat I_{2H}) at 20 mbar or
- LP gas (Cat I₃₊) Butane 29 mbar /Propane 37 mbar

NOTE: The natural gas and LP gas versions of these cookers are different models and CANNOT be converted from one gas family to the other.

INSTALLER: Please leave these instructions with the User.

DATA BADGE LOCATION: Cooker back, serial number repeater badge below oven door opening.

COUNTRY OF DESTINATION: GB, IE.

Connections

Gas (Rp ½ at rear right-hand side)		Electric
Natural gas	20 mbar	230/400V 50Hz
Butane	29 mbar	
Propane	37 mbar	

See the appliance badge for test pressures.

Dimensions

Overall height	minimum 900 mm	maximum 925 mm
Overall width	1100 mm	
Overall depth	600 mm (to fascia); 650 mm (over handles)	
Minimum space above the hotplate	650 mm	

Refer to '*Positioning the Cooker*'.

Ratings

Hotplate	Bypass Screw	Natural Gas 20 mb		L.P. Gas	
			Injector		Injector
Wok burner	57	3.5 kW	internal 78	3.5 kW (246 g/h)	internal 53
			external 126		external 82
Large burner	40	3.0 kW	134	3.0 kW (210 g/h)	87
Medium burner	32	1.7 kW	109	1.7 kW (119 g/h)	68
Small burner	28	1.0 kW	75	1.0 kW (70 g/h)	51
Grill	88	2.73 kW	190	2.73 kW (192 g/h)	85
Ovens	N/A	3.2 kW	237	2.9 kW (203 g/h)	85

Warmer	0.16 kW
--------	---------

Maximum total electrical load at 230V (approximate total including oven lights, oven fan, etc.): 0.16 kW.



Name of Appliance & Colour*				
Appliance Serial Number*				
Fuel Type*	Natural Gas	<input type="checkbox"/>	LP Gas	<input type="checkbox"/>
	Dual Fuel	<input type="checkbox"/>	Electric	<input type="checkbox"/>
Retailer's Name & Address				
Date of Purchase				
Installer's Name & Address				
Installer's Telephone Number				
Date of Installation				

* This information is on the appliance data badge – look in the appliance instructions to find out where the data badge is located.

CONSUMER SERVICE

If you have any product enquiries, or in the event of a problem with your appliance once it has been installed, please telephone 0870 789 5107.

CONSUMER SERVICE LINES OPEN:

Monday to Thursday 8am–6pm
 Friday 8am–5pm
 Saturday 9am–1pm

WARRANTY

Your manufacturer warranty covers goods of our own brand for defective workmanship and materials for a period of 3 year from the date of purchase. This warranty covers mechanical breakdown and proven cosmetic and manufacturing defects.

To register for this guarantee simply fill in and return the FREEPOST registration form provided. Alternatively call free on 0800 694 4170, quoting reference FAGX91AN or register online at www.falconappliances.co.uk

Any damage, blemishes or chips identified upon receipt of the product must be reported within 90 days ñ proof of purchase may be required to establish validity. Scratches on the surface of ceramic hobs must be reported within 14 days. Scratches caused by usage are not covered. Accidental damage is not covered by the manufacturer's warranty.

For warranty compliance, the requirements are that the appliance:

- Has been correctly installed in accordance with current legislation, relevant British and European Standards and Codes of Practice, by a suitably competent person registered with Gas Safe or equivalent body and, where applicable, a qualified electrician.
- Has been used solely for domestic cooking purposes.
- Is in use in the UK*, has not been taken abroad as a personal export. (In the Republic of Ireland conditions may vary, so consult your retailer.)
- Is not second-hand or a refurbished appliance. The manufacturer's warranty is not transferable.
- Has not been subject to misuse, accidental damage or modification, and has not deteriorated due to normal domestic wear and tear, and the manufacturer's recommendations concerning cleaning materials have been followed.
- Has not been repaired by persons or organisations other than those authorised to act on behalf of AGA Rangemaster.

Exceptions:

- Items not included under the free 3 year guarantee include pan supports, griddles, wok rings, baking trays, grill pans, trivets, filters, light bulbs and other consumable accessories.
- Any damage caused other than through normal use.
- Breakdowns associated with cooking spillage.
- Cosmetic deterioration deemed to be normal wear and tear.

This warranty is in addition to your Statutory Rights.

* Only certain models can be adapted for use with Mains Gas supplied in the Channel Islands and Isle of Man.

OUT OF WARRANTY

We recommend that Falcon appliances are serviced regularly throughout their life to maintain optimum performance and efficiency. Service work should only be carried out by technically competent and suitably qualified personnel.

For your own safety, always make sure that work is carried out by a Gas Safe registered engineer for gas appliances or an approved electrician for electrical models.

For a competitive quote and to arrange for a Falcon approved engineer to attend, call Consumer Services on: 0870 789 5107.

SPARE PARTS

To maintain optimum and safe performance, we recommend that only genuine Falcon spare parts are used. These are available from most major spares stockists, including ourselves.

Contact Consumer Services on 0870 789 5107, who will be happy to help.

STANDARDS

Falcon cookers are designed and manufactured to a recognised international quality standard, which meets the requirements of BS EN ISO 9001, BS EN ISO 14001 and OHSAS 18001 for continually improving environmental procedures.

Falcon cookers comply with the essential requirements of the appropriate European Directives, and carry the CE mark.



DIVERTIMENTI

For over 45 years
DIVERTIMENTI, Falcon's
sister company, has
been the ultimate destination
for food lovers and serious
chefs alike. With its vast array
of cookware, tableware and
kitchenware, DIVERTIMENTI
caters to all your culinary needs.
With over 4500 items on the
DIVERTIMENTI
website www.divertimenti.co.uk



Falcon Appliances
Clarence Street
Royal Leamington Spa
Warwickshire
CV31 2AD
Tel 0870 755 6490
Fax 0192 631 1032

Email consumers@falconappliances.co.uk
www.falconappliances.co.uk
Trade Enquiries 0115 946 6143
Email sales@falconappliances.co.uk

Registered in England and Wales. Registration No. 354715 Registered Office: Juno Drive, Leamington Spa, Warwickshire, CV31 3RG

Falcon continuously seeks improvements in specification, design and production of products and thus, alterations take place periodically. Whilst every effort is made to produce up-to-date literature, this booklet should not be regarded as an infallible guide to current specification, nor does it constitute an offer for the sale of any particular appliance.

